

# TTF200

## Field-mount temperature transmitter



Temperature transmitter for HART protocol.  
Suitable for all standard requirements

### Measurement made easy

TTF200

### Introduction

The TTF200 with the 4 to 20 mA output and HART communications protocol has global approvals for explosion protection up to Zone 0. Safety-relevant applications up to SIL 3 (redundant) are supported in accordance with IEC 61508.

The TTF200 features a universal sensor input for resistance thermometer, thermocouples, resistance- and voltage measurement.

### Additional Information

Additional documentation on TTF200 is available for download free of charge at [www.abb.com/temperature](http://www.abb.com/temperature). Alternatively simply scan this code:



## Table of contents

<b>1 Safety</b> .....	<b>3</b>	<b>7 Electrical connections</b> .....	<b>17</b>
General information and instructions.....	3	Safety instructions .....	17
Warnings.....	3	Protection of the transmitter from damage caused by	
Intended use .....	4	highly energetic electrical interferences .....	17
Improper use.....	4	Suited protective measures.....	18
Warranty provisions.....	4	Conductor material .....	18
Notes on data safety .....	4	Power supply cable.....	18
Manufacturer's address .....	4	Cable glands .....	18
<b>2 Use in potentially explosive atmospheres in</b>		Shielding of the sensor connection cable.....	18
<b>accordance with ATEX and IECEx</b> .....	<b>5</b>	Examples of shielding / grounding.....	19
Ex marking.....	5	Pin assignment.....	21
Transmitter .....	5	Terminal for sensor connection cable .....	22
LCD indicator .....	5	Electrical data for inputs and outputs.....	22
Temperature data .....	6	Input - resistance thermometer / resistances .....	22
Transmitter .....	6	Input - thermocouples / voltages.....	23
LCD indicator .....	6	Output.....	23
Electrical data .....	6	Power supply .....	24
Transmitter .....	6	<b>8 Commissioning</b> .....	<b>25</b>
LCD indicator .....	7	General.....	25
Installation instructions.....	7	Checks prior to commissioning.....	25
ATEX / IECEx .....	7	Communication .....	25
Cable entries .....	7	Parameterization of the device .....	26
Electrical connections .....	9	Parameter descriptions .....	27
Grounding.....	9	Factory settings .....	29
Intrinsic safety installation check .....	9	Basic Setup .....	30
Installation in a potentially explosive atmosphere .....	9	Sensor error adjustment (DTM adjustment function)	
Commissioning.....	12	.....	30
Operating instructions.....	12	HART variables.....	31
Damage to the 'Flameproof (enclosure)– Ex d' type of		Communication / HART TAG / device addressing .....	31
protection.....	12	<b>9 Operation</b> .....	<b>31</b>
Protection against electrostatic discharges.....	12	Safety instructions .....	31
Repair .....	12	Process display .....	31
<b>3 Design and function</b> .....	<b>13</b>	Error messages on the LCD display .....	32
General .....	13	<b>10 Diagnosis / error messages</b> .....	<b>32</b>
<b>4 Product identification</b> .....	<b>13</b>	Messages via the HART interface .....	32
Name plate .....	13	Error message on the LCD display .....	32
<b>5 Transport and storage</b> .....	<b>15</b>	Error message on the current output .....	32
Inspection.....	15	Possible error messages – HART® .....	33
Transporting the device.....	15	<b>11 Maintenance</b> .....	<b>34</b>
Storing the device .....	15	Safety instructions .....	34
Ambient conditions .....	15	Cleaning.....	34
Returning devices.....	15	<b>12 Repair</b> .....	<b>34</b>
<b>6 Installation</b> .....	<b>15</b>	Safety instructions .....	34
Opening and closing the housing .....	16	Returning devices .....	34
Rotating the LCD indicator .....	16	<b>13 Recycling and disposal</b> .....	<b>35</b>
<b>7 Electrical connections</b> .....	<b>17</b>	<b>14 Specification</b> .....	<b>35</b>
Safety instructions .....	17	<b>15 Additional documents</b> .....	<b>35</b>
Protection of the transmitter from damage caused by		<b>16 Appendix</b> .....	<b>36</b>
highly energetic electrical interferences .....	17	Return form.....	36
Suited protective measures.....	18		
Conductor material .....	18		
Power supply cable.....	18		
Cable glands .....	18		
Shielding of the sensor connection cable.....	18		
Examples of shielding / grounding.....	19		
Pin assignment.....	21		
Terminal for sensor connection cable .....	22		
Electrical data for inputs and outputs.....	22		
Input - resistance thermometer / resistances .....	22		
Input - thermocouples / voltages.....	23		
Output.....	23		
Power supply .....	24		
<b>8 Commissioning</b> .....	<b>25</b>		
General.....	25		
Checks prior to commissioning.....	25		
Communication .....	25		
Parameterization of the device .....	26		
Parameter descriptions .....	27		
Factory settings .....	29		
Basic Setup .....	30		
Sensor error adjustment (DTM adjustment function)			
.....	30		
HART variables.....	31		
Communication / HART TAG / device addressing .....	31		
<b>9 Operation</b> .....	<b>31</b>		
Safety instructions .....	31		
Process display .....	31		
Error messages on the LCD display .....	32		
<b>10 Diagnosis / error messages</b> .....	<b>32</b>		
Messages via the HART interface .....	32		
Error message on the LCD display .....	32		
Error message on the current output .....	32		
Possible error messages – HART® .....	33		
<b>11 Maintenance</b> .....	<b>34</b>		
Safety instructions .....	34		
Cleaning.....	34		
<b>12 Repair</b> .....	<b>34</b>		
Safety instructions .....	34		
Returning devices .....	34		
<b>13 Recycling and disposal</b> .....	<b>35</b>		
<b>14 Specification</b> .....	<b>35</b>		
<b>15 Additional documents</b> .....	<b>35</b>		
<b>16 Appendix</b> .....	<b>36</b>		
Return form.....	36		

# 1 Safety

## General information and instructions

These instructions are an important part of the product and must be retained for future reference.

Installation, commissioning, and maintenance of the product may only be performed by trained specialist personnel who have been authorized by the plant operator accordingly. The specialist personnel must have read and understood the manual and must comply with its instructions.

For additional information or if specific problems occur that are not discussed in these instructions, contact the manufacturer.

The content of these instructions is neither part of nor an amendment to any previous or existing agreement, promise or legal relationship.

Modifications and repairs to the product may only be performed if expressly permitted by these instructions.

Information and symbols on the product must be observed.

These may not be removed and must be fully legible at all times.

The operating company must strictly observe the applicable national regulations relating to the installation, function testing, repair and maintenance of electrical products.

## Warnings

The warnings in these instructions are structured as follows:

### **DANGER**

The signal word '**DANGER**' indicates an imminent danger. Failure to observe this information will result in death or severe injury.

### **WARNING**

The signal word '**WARNING**' indicates an imminent danger. Failure to observe this information may result in death or severe injury.

### **CAUTION**

The signal word '**CAUTION**' indicates an imminent danger. Failure to observe this information may result in minor or moderate injury.

### **NOTICE**

The signal word '**NOTICE**' indicates possible material damage.

### **Note**

'**Note**' indicates useful or important information about the product.

## ... 1 Safety

### Intended use

This device is intended for the following uses:

- To measure the temperature of fluid, pulpy or pasty substances and gases or resistance/voltage values.

The device has been designed for use exclusively within the technical limit values indicated on the name plate and in the data sheets.

- The maximum ambient temperature must not be exceeded.
- The IP rating of the housing must be observed during operation.
- For use in potentially explosive atmospheres, follow the associated guidelines.
- When using as a SIL-device in safety-relevant applications, the SIL Safety Manual should be observed.

### Improper use

The following are considered to be instances of especially improper use of the device:

- For use as a climbing aid, for example for mounting purposes.
- For use as a bracket for external loads, for example as a support for piping, etc.
- Material application, for example by painting over the housing, name plate or welding/soldering on parts.
- Material removal, for example by spot drilling the housing.

### Warranty provisions

Using the device in a manner that does not fall within the scope of its intended use, disregarding this manual, using underqualified personnel, or making unauthorized alterations releases the manufacturer from liability for any resulting damage. This renders the manufacturer's warranty null and void.

### Notes on data safety

This product is designed to be connected to and to communicate information and data via a network interface. It is operator's sole responsibility to provide and continuously ensure a secure connection between the product and your network or any other network (as the case may be). Operator shall establish and maintain any appropriate measures (such as but not limited to the installation of firewalls, application of authentication measures, encryption of data, installation of anti-virus programs, etc.) to protect the product, the network, its system and the interface against any kind of security breaches, unauthorized access, interference, intrusion, leakage and / or theft of data or information. ABB Automation Products GmbH and its affiliates are not liable for damages and / or losses related to such security breaches, any unauthorized access, interference, intrusion, leakage and / or theft of data or information.

### Manufacturer's address

#### ABB Automation Products GmbH Measurement & Analytics

Schillerstr. 72  
32425 Minden  
German  
Tel: +49 571 830-0  
Fax: +49 571 830-1806

#### Customer service center

Tel: +49 180 5 222 580  
Email: [automation.service@de.abb.com](mailto:automation.service@de.abb.com)

## 2 Use in potentially explosive atmospheres in accordance with ATEX and IECEx

### Note

- Further information on the approval of devices for use in potentially explosive atmospheres can be found in the explosion protection test certificates (at [www.abb.com/temperature](http://www.abb.com/temperature)).
- Depending on the design, a specific marking in accordance with ATEX or IECEx applies.
- In devices with combined types of protection, for example TTF200-E4, observe the 'Product Identification' chapter in the operating or commissioning instruction before commissioning.

### Ex marking

#### Transmitter

##### ATEX intrinsic safety

The device fulfills the requirements of Directive 2014/34/EU in case of corresponding purchase orders and is approved for use in Zone 0, 1 and 2.

##### Model TTF200-E1

Type Examination Test Certificate	PTB 05 ATEX 2017 X
II 1 G Ex ia IIC T6 Ga	
II 2 (1) G Ex [ia IIC Ga] ib IIC T6 Gb	
II 2 G (1D) Ex [ia IIIC Da] ib IIC T6 Gb	

##### ATEX flameproof (enclosure)

Approved for use in Zone 1 and 2.

##### Model TTF200-E3

Type Examination Test Certificate	PTB 99 ATEX 1144 X
II 2G Ex db IIC T6/T4 Gb	

##### ATEX flameproof (enclosure) and intrinsic safety

Approved for use in Zone 1 and 2, in case of intrinsic safety also for use in Zone 0.

The 'E4' coding combines the following types of protection: 'Intrinsic safety', (TTF200-E1) and 'Flameproof (enclosure)', (TTF200-E3). Devices with combined types of protection may only be operated in one of the possible types of protection. For this purpose, observe the 'Product Identification' chapter in the operating or commissioning instruction before commissioning.

##### Model TTF200-E4

Type Examination Test Certificate	PTB 99 ATEX 1144 X
	PTB 05 ATEX 2017 X
II 2G Ex db IIC T6/T4 Gb	
II 1G Ex ia IIC T6 Ga	

##### IECEx intrinsic safety

Approved for use in Zone 0, 1, and 2.

##### Model TTF200-H1

IECEx certificate of conformity	IECEx PTB 09.0014X
Ex ia IIC T6...T1 Ga	
Ex [ia IIC Ga] ib IIC T6...T1 Gb	
Ex [ia IIIC Da] ib IIC T6...T1 Gb	

##### IECEx flameproof (enclosure)

Approved for use in Zone 1 and 2.

##### Model TTF200-H5

IECEx certificate of conformity	IECEx PTB 12.0039 X
Ex db IIC T6/T4 Gb	

### LCD indicator

##### ATEX intrinsic safety

The device fulfills the requirements of Directive 2014/34/EU in case of corresponding purchase orders and is approved for use in Zone 0, 1 and 2.

##### Type Examination Test Certificate

PTB 05 ATEX 2079 X
--------------------

II 1G Ex ia IIC T6 Ga

##### IECEx intrinsic safety

Approved for use in Zone 0, 1, and 2.

##### IECEx certificate of conformity

IECEx PTB 12.0028X
--------------------

Ex ia IIC T6

## ... 2 Use in potentially explosive atmospheres in accordance with ATEX and IECEx

### Temperature data

#### Transmitter

##### ATEX / IECEx intrinsic safety

Temperature class	Permissible ambient temperature range	
	Device category 1 use	Device category 2 / 3 use
T6	-40 to 44 °C (-40 to 111.2 °F)	-40 to 56 °C (-40 to 132.8 °F)
T4-T1	-40 to 60 °C (-40 to 140.0 °F)	-40 to 85 °C (-40 to 185.0 °F)

##### ATEX / IECEx Flameproof (Enclosure)

Temperature class	Permissible ambient temperature range on the connection head
T6	-40 to 67 °C (-40 to 152 °F)
T4 to T1	-40 to 85 °C (-40 to 185 °F)

#### LCD indicator

##### ATEX / IECEx intrinsic safety

Temperature class	Permissible ambient temperature range	
	Device category 1 use	Device category 2 / 3 use
T6	-40 to 44 °C (-40 to 111.2 °F)	-40 to 56 °C (-40 to 132.8 °F)
T4-T1	-40 to 60 °C (-40 to 140 °F)	-40 to 85 °C (-40 to 185 °F)

### Electrical data

#### Transmitter

##### Intrinsic safety type of protection Ex ia IIC (Part 1)

Supply circuit	
Max. voltage	$U_i = 30 \text{ V}$
Short-circuit current	$I_i = 130 \text{ mA}$
Max. power	$P_i = 0.8 \text{ W}$
Internal inductance	$L_i = 160 \text{ } \mu\text{H}$
Internal capacitance	$C_i = 0.57 \text{ nF}$

##### Intrinsic safety type of protection Ex ia IIC (Part 2)

Measurement current circuit		
	Resistance Thermocouples, voltages thermometers, resistors	
Max. voltage	$U_o = 6.5 \text{ V}$	$U_o = 1.2 \text{ V}$
Short-circuit current	$I_o = 17.8 \text{ mA}$	$I_o = 50 \text{ mA}$
Max. power	$P_o = 29 \text{ mW}$	$P_o = 60 \text{ mW}$
Internal inductance	$L_i = 0 \text{ mH}$	$L_i = 0 \text{ mH}$
Internal capacitance	$C_i = 118 \text{ nF}$	$C_i = 118 \text{ nF}$
Maximum permissible external inductance	$L_o = 5 \text{ mH}$	$L_o = 5 \text{ mH}$
Maximum permissible external capacitance	$C_o = 1.55 \text{ } \mu\text{F}$	$C_o = 1.05 \text{ } \mu\text{F}$

##### Intrinsic safety type of protection Ex ia IIC (Part 3)

LCD indicator interface	
Max. voltage	$U_o = 6.2 \text{ V}$
Short-circuit current	$I_o = 65.2 \text{ mA}$
Max. power	$P_o = 101 \text{ mW}$
Internal inductance	$L_i = 0 \text{ mH}$
Internal capacitance	$C_i = 0 \text{ nF}$
Maximum permissible external inductance	$L_o = 5 \text{ mH}$
Maximum permissible external capacitance	$C_o = 1.4 \text{ } \mu\text{F}$

**Type of protection flameproof (enclosure) Ex db IIC****Supply circuit**

Maximum voltage	$U_S = 30 \text{ V}$
Maximum current	$I_S = 32 \text{ mA}$ , limited by the upstream fuse (rated fuse current 32 mA)

**Measurement current circuit**

Maximum voltage	$U_O = 6.5 \text{ V}$
Maximum current	$I_O = 17.8 \text{ mA}$
Maximum power	$P_O = 29 \text{ mW}$

**LCD indicator****Intrinsic safety type of protection Ex ia IIC****Supply circuit**

Max. voltage	$U_i = 9 \text{ V}$
Short-circuit current	$I_i = 65.2 \text{ mA}$
Max. power	$P_i = 101 \text{ mW}$
Internal inductance	$L_i = 0 \text{ mH}$
Internal capacitance	$C_i = 0 \text{ nF}$

**Installation instructions****ATEX / IECEx**

The installation, commissioning, maintenance and repair of devices in potentially explosive atmospheres must only be carried out by appropriately trained personnel. Works may be carried out only by persons, whose training has included instructions on different types of protection and installation techniques, concerned rules and regulations as well as general principles of zoning. The person must possess the appropriate competences for the type of work to be conducted.

When operating with combustible dusts, comply with EN 60079-31.

The safety instructions for electrical apparatus in potentially explosive areas must be in accordance with Directive 2014/34/EU (ATEX) and IEC 60079-14 (Installation of electrical equipment in potentially explosive areas).

Comply with the applicable regulations for the protection of employees to ensure safe operation.

**Cable entries****Devices with type of protection 'Ex d' without supplied cable glands**

For devices with type of protection 'Ex d – flameproof (enclosure)' supplied without cable glands, refer to the notices in **ATEX - Zone 1 (20)** on page 10 and **Flameproof (enclosure) - Zone 1** on page 11.

For information on the cable gland used, refer to the relevant data sheet and operating instructions.

**Devices with type of protection 'Ex d' with cable glands**

If devices in 'Ex d – flameproof (enclosure)' type of protection with cable gland are ordered, an Ex d certified cable gland is factory-installed.

**Cable gland data**

- Thread:  $2 \times \text{M}20 \times 1.5$  or  $2 \times \frac{1}{2}$  in NPT
- Temperature range:  $-50$  to  $85 \text{ }^\circ\text{C}$  ( $-58$  to  $185 \text{ }^\circ\text{F}$ )
- Cable outside diameter: 3.2 to 8.7 mm (0.13 to 0.34 in)
- Material: nickel-plated brass

The cable entry is only suitable for fixed installations and non-reinforced cables with round and smooth plastic sleeves and suitable outside diameter. The cables must be attached appropriately in order to prevent them being pulled out or twisted.

The operating instruction and approvals supplied with the cable glands, as well as any applicable requirements in accordance with EN 60079-14 must be taken into account accordingly.

## ... 2 Use in potentially explosive atmospheres in accordance with ATEX and IECEx

### Installation instructions for cable glands

The sealing rings of the cable glands harden at low temperatures. Before installation, bring the sealing rings to a temperature of at least 20 °C for 24 hours. Before inserting the sealing rings and fixing them onto the cable gland, knead the rings to ensure they are soft and flexible.

IP rating IP66 / 67 is only achieved by installing the black neoprene sealing ring between the cable gland and the housing and by observing the tightening torque of 3.6 Nm (Figure 2, item ②).

Cables must be protected against extreme mechanical loads (caused by tension, torsion, crushing, and so on). Even under operating conditions, it must be ensured that the cable entry remains hermetically sealed. The customer must provide a strain relief device for the cable.

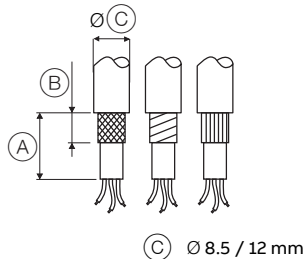

Ⓐ 40 mm

Ⓒ Ø 8.5 / 12 mm

Ⓑ 12 mm

Figure 1: Stripping the connection cable

1. Check that cable used is suitable (i.e., check the mechanical resilience, temperature range, creep resistance, resistance to chemicals, outside diameter, and so on).
2. Strip the cable in accordance with Figure 1.
3. Check the outer sleeve for damage and soiling.
4. Insert the cable in the cable gland.

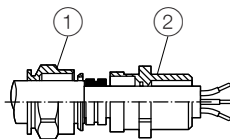

Figure 2: Tighten cable glands

5. Tighten the cable gland until the cable is firmly enclosed by the sealing ring (Figure 2, item ①). Do not tighten more than 1.5--times of the specified torque on the housing (see assembly instructions for cable gland)!

### Maintenance

Check the cable glands during each maintenance session. If the cable is slack, retighten the cap(s) of the cable glands.

If it is not possible to retighten them, the cable gland will need to be replaced.

### M20 × 1.5 plastic cable gland for various types of protection

The optionally supplied M20 × 1.5 plastic cable gland has a limited temperature range. The permissible ambient temperature range of the cable gland is -20 to 80 °C (-4 to 176 °F). When using the cable gland, make sure that the ambient temperature is within this range.

The cable gland must be installed in the housing with a tightening torque of 3.8 Nm. On the cable side, when installing the connection of the cable gland and cable, check for integrity to ensure that the required IP rating is met.



## Electrical connections

### Grounding

If, for functional reasons, the intrinsically safe circuit needs to be grounded by means of a connection to the potential equalization, it may only be grounded at one point.

### Intrinsic safety installation check

If transmitters are operated in an intrinsically safe circuit, proof that the interconnection is intrinsically safe must be provided in accordance with IEC/EN 60079-14 as well as IEC/EN 60079-25. The supply isolators / DCS inputs must feature intrinsically safe input protection circuits in order to eliminate hazards (spark formation).

In order to provide proof of intrinsic safety, the electrical limit value must be used as the basis for the EC-type examination certificates for the equipment (devices); this includes the capacitance and inductance values of the cables. Proof of intrinsic safety is said to have been provided if the following conditions are fulfilled when a comparison is carried out in relation to the limit values of the equipment:

Transmitter (intrinsically safe equipment)	Supply isolator / DCS input (related equipment)
$U_i \geq U_o$	
$I_i \geq I_o$	
$P_i \geq P_o$	
$L_i + L_c \text{ (cable)} \leq L_o$	
$C_i + C_c \text{ (cable)} \leq C_o$	

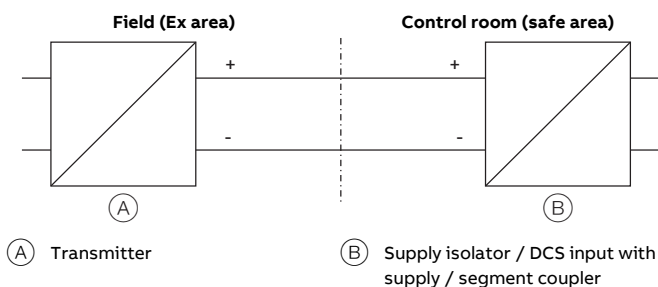

Figure 3: Intrinsic safety installation check

### Installation in a potentially explosive atmosphere

Transmitters can be installed in all kinds of industrial sectors. Potentially explosive systems are divided into zones, meaning that a wide range of different instruments are also required. For this, pay attention to the country-specific guidelines and certificates!

### Note

Ex relevant specifications must be taken from the EC-type examination certificates and other relevant certificates that apply in each case.

### ATEX - Zone 0

Designation: II 1 G Ex ia IIC T6 Ga

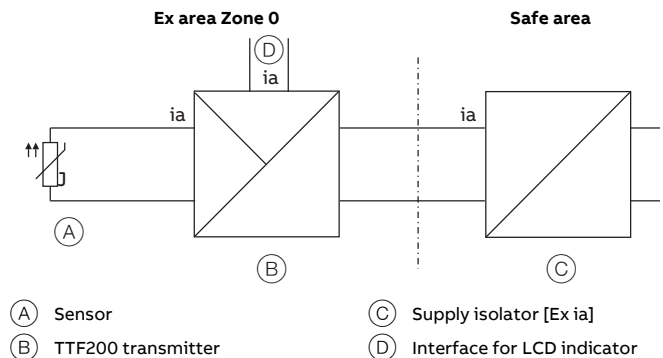

Figure 4: Hookup in ATEX - Zone 0

The input for the supply isolator must be designed with 'Ex ia' type of protection.

When using the transmitter in Zone 0, make sure that impermissible electrostatic charging of the transmitter is avoided (observe the warnings on the device).

As the user, it is your responsibility to ensure that the sensor instrumentation meets the requirements of applicable explosion protection standards.

### WARNING

#### Risk of explosion!

When using the device in areas that require the device safety level EPL 'Ga' (Zone 0), the TTF200 types must be installed with aluminum housings, protected against mechanical impacts or friction.

### Note

When operating the transmitter in Zone 0 (EPL 'Ga'), the compatibility of the device materials with the surrounding atmosphere must be ensured.

Encapsulation material used for the transmitter:

Polyurethane (PUR), WEVO PU-417

## ... 2 Use in potentially explosive atmospheres in accordance with ATEX and IECEx

### ... Electrical connections

#### ATEX - Zone 1 (0)

Marking: II 2 (1) G Ex [ia IIC Ga] ib IIC T6 Gb

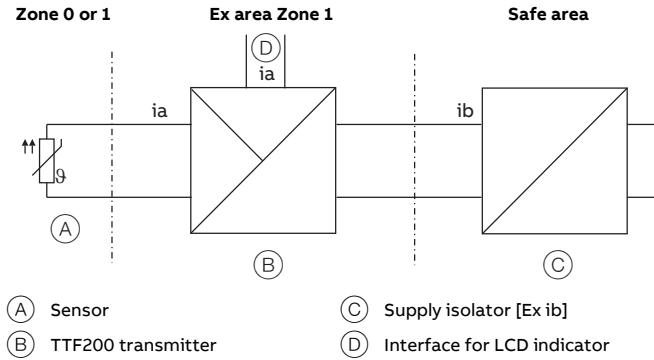

Figure 5: Hookup in ATEX - Zone 1 (0)

The input for the supply isolator must be designed with 'Ex ib' type of protection.

As the user, it is your responsibility to ensure that the sensor instrumentation meets the requirements of applicable explosion protection standards.

The sensor can be installed in Zone 1 or Zone 0.

When using the transmitter in Zone 1, you must ensure that impermissible electrostatic charging of the temperature transmitter is prevented (observe the warnings on the device).

#### ATEX - Zone 1 (20)

Marking: II 2 G (1D) Ex [ia IIIC Da] ib IIC T6 Gb

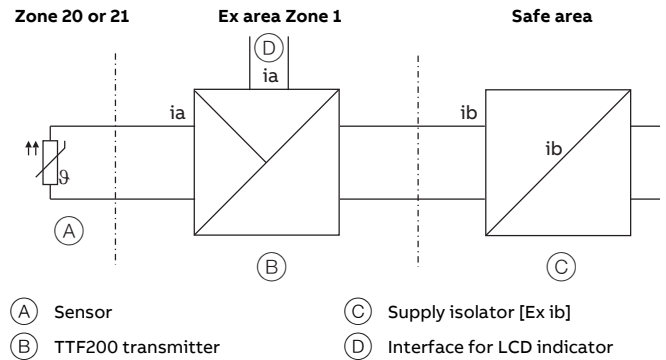

Figure 6: Hookup in ATEX - Zone 1 (20)

The input for the supply isolator must be designed with 'Ex ib' type of protection.

As the user, it is your responsibility to ensure that the sensor instrumentation meets the requirements of applicable explosion protection standards.

The sensor can be installed in Zone 20 or Zone 21.

When using the transmitter in Zone 1, make sure that impermissible electrostatic charging of the temperature transmitter is avoided (observe the warnings on the device).

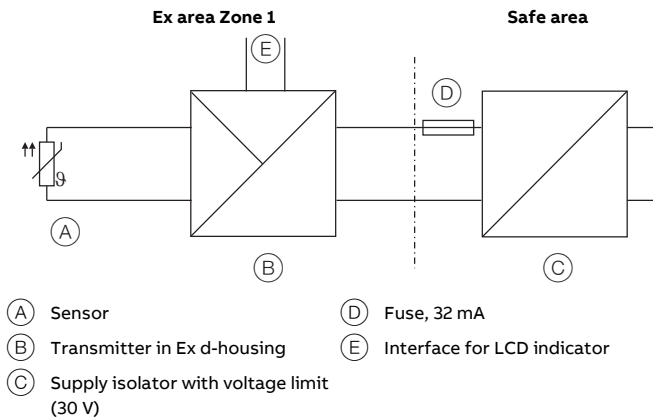
**Flameproof (enclosure) - Zone 1****Housing design: ATEX II 2G Ex db IIC T6/T4 Gb****Figure 7: Hookup in Zone 1 'flameproof (enclosure)' type of protection**

The power supply circuit of the transmitter must be limited by an upstream fuse with a fuse current rating of 32 mA.

Maximum input terminal voltage of the transmitter: 30 V DC

The 'flameproof enclosure' type of protection is only achieved by correctly installing a specially certified cable gland with the Ex d type of protection with the corresponding marking.

The sensor instrumentation must be provided by the user in accordance with the valid Ex-standards.

As far as the installation and mounting of components is concerned (explosion-proof cable entries, connection parts), only those components are approved which at the least technically comply with the current version of the PTB 99 ATEX 1144 X type examination certificate and for which a separate examination certificate exists. At the same time, it is imperative that the operating conditions listed in the respective component certificates are complied with.

The transmitter must be connected using suitable cable and cable entries or pipeline systems that satisfy the requirements of EN 60079-1 and for which a separate examination certificate exists. If the transmitter is connected to pipeline systems, the relevant sealing device must be affixed directly to the housing. Cable entries (PG glands) and sealing plugs of simple design must not be used.

Close unused cable entry in accordance with EN 60079.-1.

The connection lead must be routed securely and in such a way as to ensure adequate protection against damage.

If the temperature on the entry parts is over 70° C, connection leads with sufficient temperature resistance must be used.

The transmitter must be integrated into the local potential equalization of the potentially explosive area.

## ... 2 Use in potentially explosive atmospheres in accordance with ATEX and IECEx

### Commissioning

The commissioning and parameterization of the device may also be carried out in potentially explosive atmospheres using a handheld terminal that has been approved accordingly under consideration of an intrinsic safety installation check. Alternatively, an Ex modem can be connected to the circuit outside the potentially explosive atmosphere.

### Operating instructions

#### **DANGER**

##### **Risk of explosion due to hot parts**

Hot parts inside the device pose an explosion hazard.

- Never open the device immediately after switch-off.
- A waiting time of at least four minutes should be observed before opening the device.

#### **DANGER**

##### **Explosion hazard when opening the device**

Explosion hazard when opening the device with activated power supply.

- Before opening the device, switch off the power supply.

### Damage to the 'Flameproof (enclosure)- Ex d' type of protection

The cover thread is used as a flameproof joint for the 'Flameproof (enclosure) – Ex d' type of protection.

- During assembly / disassembly of the device, make sure that the cover thread does not get damaged.
- Devices with damaged threads must no longer be used in potentially explosive atmospheres.

### Protection against electrostatic discharges

The painted surface of the housing and the plastic parts inside the device can store electrostatic charges.

#### **WARNING**

##### **Risk of explosion!**

The device must not be used in areas in which process-related electrostatic charging of the housing may occur.

- The device must be maintained and cleaned so that any dangerous electrostatic charge is avoided.

### Repair

#### **DANGER**

##### **Explosion hazard**

Explosion hazard due to improper repair of the device. Faulty devices must not be repaired by the operator.

- Any repair may only be performed in the production plant or by workshops authorized by ABB.
- Repairs on flameproof joints are not permitted.

## 3 Design and function

### General

TTF200 digital transmitters are communication-ready devices with microprocessor-controlled electronics.

For bidirectional communication, the 4 to 20 mA output signal is superimposed with an FSK signal in accordance with the HART standard.

The transmitters can be configured, polled, and tested using a DTM, an EDD or using the Field Information Manager (FIM). Handheld terminals can also be used for communication purposes.

As an option, the transmitter can be fitted with the type BS LCD indicator. The LCD indicator is used to visualize the current process values.

### Note

A configuration of the TTF200 with the type B LCD indicator with the configuration function used in the TTF300 is not possible.

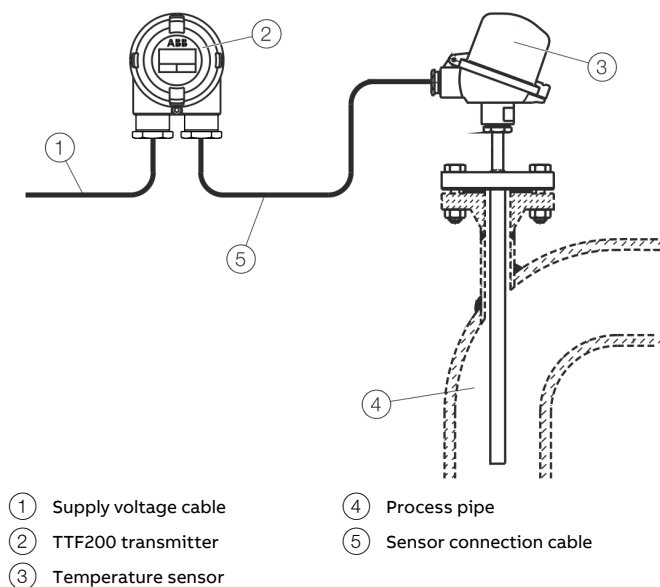

Figure 8: Setup of the TTF200

## 4 Product identification

### Name plate

#### Note



Products that are marked with the adjacent symbol may **not** be disposed of as unsorted municipal waste (domestic waste).

They should be disposed of through separate collection of electric and electronic devices.

#### Note

The ambient temperature range specified on the name plate refers only to the transmitter itself and not to the measuring element used in the measuring inset.

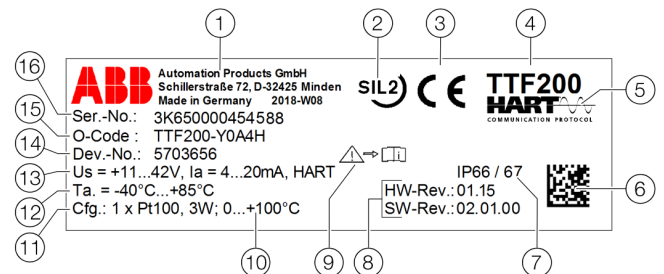

- |   |  |
|---|--|
| ① Manufacturer, manufacturer address, country of manufacture, manufacturing year - week | ⑪ Client configuration: set sensor type and circuit type   |
| ② Safety integrity level, SIL logo (optional)   | ⑫ Ambient temperature range, on additional plate for Ex versions   |
| ③ CE mark (EU conformity), if not on additional plate                                   | ⑬ Transmitter specification (supply voltage range, output current range, communications protocol)                        |
| ④ Type designation / model  | ⑭ 7-digit serial number of the device electronic unit  |
| ⑤ Transmitter communications protocol (HART)  | ⑮ Device order coding: contains coding of type of protection, housing/indicator, cable entry and communications protocol |
| ⑥ 2D barcode for serial number in accordance with order                                 | ⑯ Serial number of the device (serial number in accordance with order)   |
| ⑦ IP rating of the housing  |  |
| ⑧ Software revision (SW), hardware revision (HW)  |  |
| ⑨ 'Follow product documentation' symbol   |  |
| ⑩ Client configuration: set measuring range of the transmitter                          |  |

Figure 9: Name plate (example)

## ... 4 Product identification

### ... Name plate

#### Explosion protection marking for devices with one type of protection

Devices with an explosion-proof design are marked with the following additional plates.

#### Note

- Further information on the approval of devices for use in potentially explosive atmospheres can be found in the explosion protection test certificates (at [www.abb.com/temperature](http://www.abb.com/temperature)).
- Depending on the design, a specific marking in accordance with ATEX or IECEx applies.

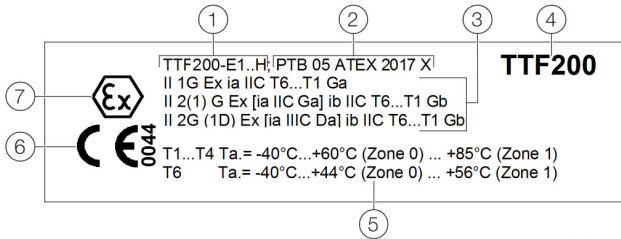

- ① Type designation in accordance with approval
- ② Approval number
- ③ Protection class of the explosion-proof design (explosion protection marking)
- ④ Type designation
- ⑤ Temperature class of the explosion-proof design
- ⑥ CE mark (EU conformity) and notified body for quality assurance
- ⑦ Ex marking

Figure 10: Additional plate for explosion-protected apparatus (example)

#### Explosion protection marking for devices with a combination of explosion protection types

Coding of the type of protection of the device in accordance with order information can also refer to a combination of different explosion approvals for various types of protection.

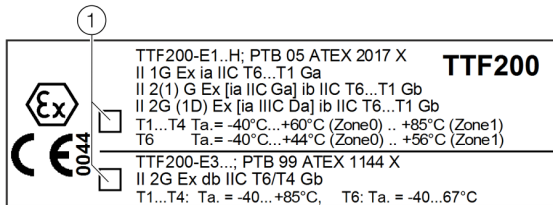

- ① Checkboxes for marking type of protection

Figure 11: Combination of 'Intrinsic safety' and 'Flameproof (enclosure)' types of protection, coding of type of protection: E4.

#### Measures required before the use of devices with combined types of protection

### NOTICE

#### Note for temperature transmitters with combined approval

Before the transmitter is installed, the selected type of protection must be permanently marked on the explosion certification plate.

The transmitter can then only be operated with this type of protection throughout its entire service life.

- If two protection types are indelibly marked on the explosion protection certification plate, the transmitter must not be used in areas categorized as hazardous.

Devices with combined types of protection may only be operated in one of the possible types of protection. Before commissioning, users must decide on one of these types of protection and their corresponding approval.

The 'E4' coding combines the following types of protection: 'Intrinsic safety', type 'TTF200-E1' and 'Flameproof (enclosure)', type 'TTF200-E3'.

The additional plate has two selection fields (see Figure 11) for marking.

It is absolutely necessary to mark one of the selection fields on the left side indelibly in accordance with the selected type of protection of the application. This has to be done before the TTF200 is commissioned in the application.

The marking must be applied in a permanent and indelible manner, for example using a caustic or acidic pencil or by stamping on a metallic plate.

Unmarked devices must **NOT** be commissioned.

## 5 Transport and storage

### Inspection

Check the devices immediately after unpacking for possible damage that may have occurred from improper transport. Details of any damage that has occurred in transit must be recorded on the transport documents. All claims for damages must be submitted to the shipper without delay and before installation.

### Transporting the device

Observe the following instructions:

- Do not expose the device to humidity during transport. Pack the device accordingly.
- Pack the device so that it is protected against vibrations during transport, for example, by using air-cushioned packing.

### Storing the device

Bear the following points in mind when storing devices:

- Store the device in its original packaging in a dry and dust-free location.
- Observe the permitted ambient conditions for transport and storage.
- Avoid storing the device in direct sunlight.
- In principle, the devices may be stored for an unlimited period. However, the warranty conditions stipulated in the order confirmation of the supplier apply.

### Ambient conditions

The ambient conditions for the transport and storage of the device correspond to the ambient conditions for operation of the device.

Adhere to the device data sheet!

### Returning devices

For the return of devices, follow the instructions in **Repair** on page 34.

## 6 Installation

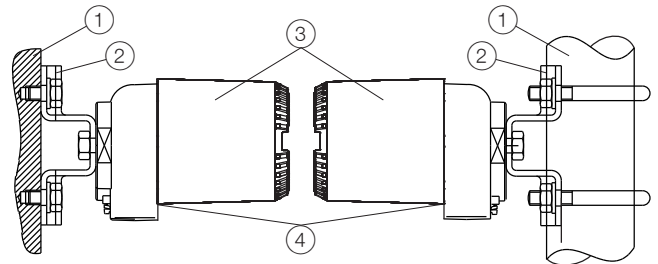

- |               |                 |
|---------------|-----------------|
| ① Wall / Pipe | ③ Transmitter   |
| ② Bracket     | ④ Locking screw |

Figure 12: Installation variants

### ⚠ CAUTION

#### Risk of injury!

There is a risk of injury if the transmitter falls out due to improper mounting.

- Make sure that transmitter is securely fastened.

#### Wall mounting:

Fasten the wall bracket to the wall using 4 screws (Ø 10 mm)

#### Pipe mounting:

Attach the pipe mount to the pipe using 2 pipe clamps (Ø 10 mm). The pipe mount can be fastened to a pipe with a maximum diameter of 63.5 mm (2.5 in)

## ... 6 Installation

### Opening and closing the housing

#### **⚠ DANGER**

**Danger of explosion if the device is operated with the transmitter housing or terminal box open!**

While using the device in potentially explosive atmospheres before opening the transmitter housing or the terminal box, note the following points:

- A valid fire permit must be present.
- Make sure that no flammable or hazardous atmospheres are present.

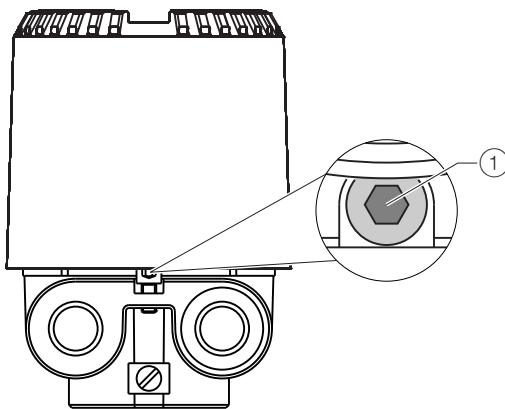

Figure 13: Cover lock (example)

To open the housing, release the cover lock by screwing in the Allen screw (1).

After closing the housing, lock the housing cover by unscrewing the Allen screw (1).

#### **NOTICE**

**Potential adverse effect on the IP rating**

- Check the O-ring gasket for damage and replace it if necessary before closing the housing cover.
- Check that the O-ring gasket is properly seated when closing the housing cover.

### Rotating the LCD indicator

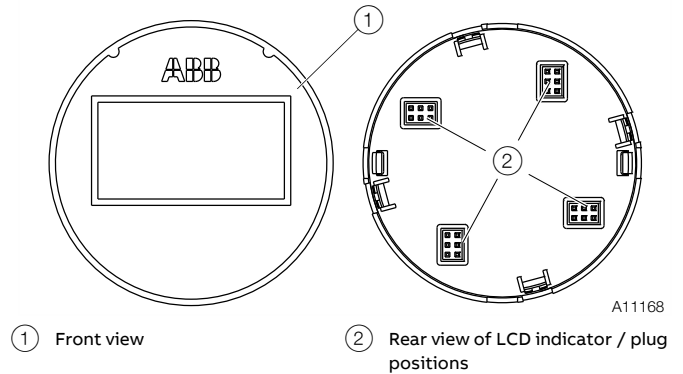

Figure 14: LCD indicator

The position of the LCD indicator can be adjusted to suit the mounting position of the transmitter, to ensure that the display is as clearly legible as possible. There are 4 positions at increments of 90°.

To adjust the position, proceed as follows:

1. Tighten the lock screw under the housing cover.
2. Release the housing cover by turning it counterclockwise.
3. Carefully pull the LCD indicator to release it from its bracket.
4. Carefully insert the LCD indicator in the required position.
5. Screw the housing cover back on.
6. Loosen the lock screw until the housing cover is firmly in place.



## 7 Electrical connections

### Safety instructions

#### **⚠ DANGER**

##### **Explosion hazard**

Improper installation and commissioning of the device carries a risk of explosion.

- For use in potentially explosive atmospheres, observe the information in **Use in potentially explosive atmospheres in accordance with ATEX and IECEx** on page 5!

Observe the following instructions:

- The electrical connection may only be established by authorized specialist personnel and in accordance with the connection diagrams.
- The relevant regulations must be observed during electric installation.
- The electrical connection information in the instruction must be observed; otherwise, the electric IP rating may be adversely affected.
- Safe isolation of electric circuits which are dangerous if touched is ensured only if the connected devices satisfy the requirements of DIN EN 61140 (VDE 0140 Part 1) (basic requirements for safe isolation).
- To ensure safe isolation, install connection leads separate from electric circuits which are dangerous if touched, or implement additional insulation measures.
- Connections must only be established in a dead-voltage state!
- The transmitter has no switch-off elements. Therefore, overcurrent protective devices, lightning protection, or voltage disconnection options must be provided with the installation.
- The power supply and signal are routed in the same conductor and should be implemented as a SELV or PELV circuit in accordance with the relevant standard (standard version). For the explosion-proof design, the guidelines in accordance with the Ex standard must be adhered to.
- You need to check that the available power supply corresponds to the information on the name plate.

#### **Note**

The signal cable wires must be provided with wire end sleeves. The slotted screws of the connection terminals are tightened with a size 1 screwdriver (3.5 or 4 mm).

### Protection of the transmitter from damage caused by highly energetic electrical interferences

The transmitter has no switch-off elements. Therefore, overcurrent protective devices, lightning protection, or voltage disconnection options must be provided at the plant. For the shielding and grounding of the device and the connection cable, observe **Examples of shielding / grounding** on page 19.

#### **NOTICE**

##### **Temperature transmitter damage!**

Overvoltage, overcurrent and high-frequency interference signals on the supply connection as well as sensor connection side of the device can damage the temperature transmitter.

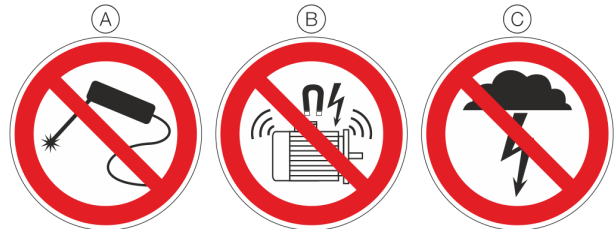

- (A) Do not weld
- (B) No high-frequency interference signals / switching operations of large consumers
- (C) No overvoltage due to lightning

Figure 15: Warning signs

Overcurrent and overvoltage can occur through for example welding operations, switching operations of large electric consumers, or lightning in the vicinity of the transmitter, sensor, as well as connector cables.

Temperature transmitters are sensitive devices on the sensor side as well. Long connector cables to the sensor can encourage damaging interference. This can already happen if temperature sensors are connected to the transmitter during installation, but are not yet integrated into the system (no connection to the supply isolator / DCS)!

## ... 7 Electrical connections

### ... Protection of the transmitter from damage caused by highly energetic electrical interferences

#### Suited protective measures

The following items should be observed to protect the transmitter from sensor-side damage:

- In the vicinity of the transmitter, sensor and sensor connector cable in case of a connected sensor, high-energy overvoltage, overcurrent and high-frequency interference signals due to welding operations, lightning, circuit breakers or large consumers of electricity among others should be absolutely avoided.
- The connection cable of the sensor on the transmitter should be disconnected when performing welding work in the vicinity of the installed transmitter, sensor, as well as supply lines from the sensor to the transmitter.
- This correspondingly also applies to the supply side, if there is a connection there.

### Conductor material

#### Power supply cable

Maximum cable outer diameter:

12 mm (0.47 in)

Maximum wire cross section:

2.5 mm<sup>2</sup> (AWG 16)

### Cable glands

The cable diameter must be appropriate for the cable gland used so that IP rating IP 66 /IP 67 or NEMA 4X can be maintained. This must be checked during installation.

For delivery without cable gland (thread M20 × 1.5 or NPT ½ in), the following points must be observed:

- Use cable glands in accordance with version M20 × 1.5 or NPT ½ in.
- Observe information in the data sheet for the cable gland used.
- Check the working temperature for the cable gland used.
- Check the IP rating IP 66 / IP 67 or NEMA 4X of the cable gland used.
- Check the Ex relevant specifications for the cable gland used in accordance with the manufacturer data sheet or the Ex declaration.
- The cable gland used must be approved for the cable diameter (IP rating).
- Observe tightening torque in accordance with information in data sheet / operating instructions for the cable gland used.

### Shielding of the sensor connection cable

To ensure the system benefits from optimum electromagnetic interference immunity, the individual system components, and the connection cables in particular, need to be shielded.

The shield must be connected to the ground reference plane.

#### Note

National regulations and directives must be observed when grounding system components.

### NOTICE

#### Damage to components!

In systems without potential equalization or with potential differences between the individual grounding points, multiple instances of shield grounding can result in transient currents at mains frequency.

These can damage the shielding, influence the measurements and have a significant impact on signal transmission, of bus signals in particular.

### Examples of shielding / grounding

#### Insulated sensor measuring inset (thermocouple, mV, RTD, ohms), transmitter housing grounded

The shielding of the sensor connection cable is grounded via the grounded transmitter housing. This shielding is insulated from the sensor.

The shielding of the power supply cable is grounded at the supply isolator / DCS input directly. This shielding is insulated from the transmitter housing.

The shielding of the power supply cable and the shielding of sensor connection cable must not be connected to one another. Make sure that the shielding is not connected to ground anywhere else.

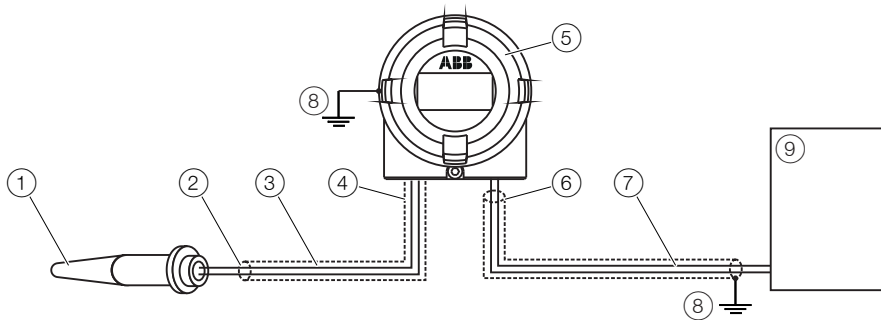

- |  |  |
|--|--|
| ① Temperature sensor                         | ⑥ Shielding insulated from transmitter housing |
| ② Shielding insulated from sensor            | ⑦ Supply voltage cable                         |
| ③ Sensor connection cable                    | ⑧ Grounding point                              |
| ④ Shielding grounded via transmitter housing | ⑨ Supply isolator / DCS input                  |
| ⑤ Transmitter housing, grounded              |  |

Figure 16: The shieldings of the sensor connection cable and the supply voltage cable are separate and each grounded at one end

#### Insulated sensor measuring inset (thermocouple, mV, RTD, ohms), transmitter housing grounded

The shielding of the sensor connection cable is grounded via the grounded sensor housing. This shielding of the power supply cable is insulated from the transmitter housing.

The shielding of the power supply cable is grounded at the supply isolator / DCS input directly. This shielding is insulated from the transmitter housing.

The shielding of the power supply cable and the shielding of sensor connection cable must not be connected to one another. Make sure that the shielding is not connected to ground anywhere else.

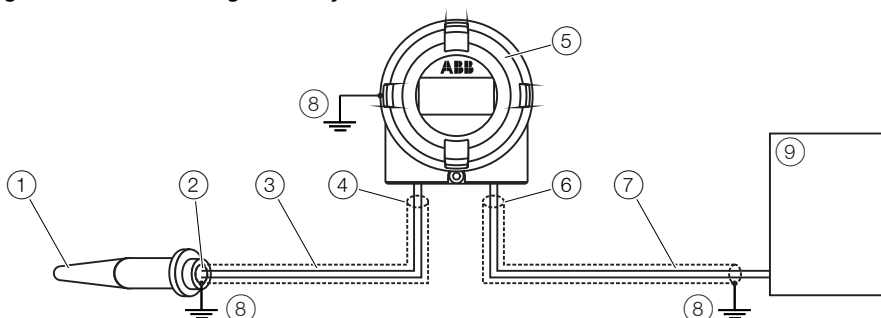

- |  |  |
|--|--|
| ① Temperature sensor                           | ⑥ Shielding insulated from transmitter housing |
| ② Shielding grounded via sensor                | ⑦ Supply voltage cable                         |
| ③ Sensor connection cable                      | ⑧ Grounding point                              |
| ④ Shielding insulated from transmitter housing | ⑨ Supply isolator / DCS input                  |
| ⑤ Transmitter housing, grounded                |  |

Figure 17: The shieldings of the sensor connection cable and the supply voltage cable are separate and each grounded at one end

## ... 7 Electrical connections

### ... Shielding of the sensor connection cable

#### Insulated sensor measuring inset (thermocouple, mV, RTD, ohms), transmitter housing not grounded

The shielding of the power supply cable and the shielding of the sensor connection cable are connected to one another via the transmitter housing. The shielding is grounded at one end of the power supply cable, directly at the supply isolator / DCS input. Make sure that the shielding is not connected to ground anywhere else.

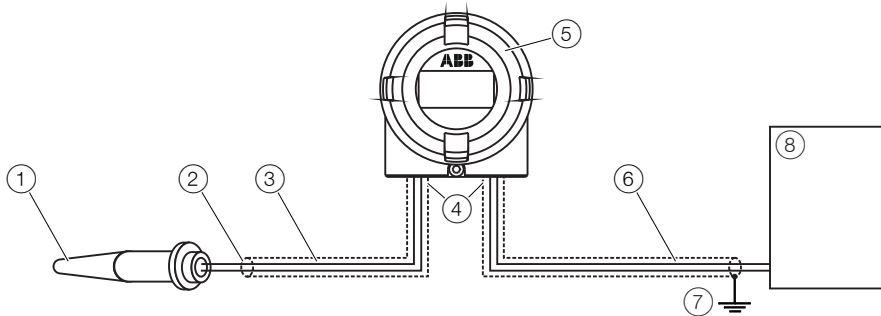

- |  |                                     |
|--|-------------------------------------|
| ① Temperature sensor                                       | ⑤ Transmitter housing, not grounded |
| ② Shielding insulated from sensor                          | ⑥ Supply voltage cable              |
| ③ Sensor connection cable                                  | ⑦ Grounding point                   |
| ④ Shielding connected electrically via transmitter housing | ⑧ Supply isolator / DCS-input       |

Figure 18: The shieldings of the sensor connection cable and the supply voltage cable are connected electrically via the transmitter housing and grounded at one end

#### Non-insulated sensor measuring inset (thermocouple), transmitter housing grounded

The shielding of the sensor connection cable is grounded via the grounded pressure sensor housing. This shielding of the power supply cable is insulated from the transmitter housing.

The shielding of the power supply cable is grounded at the supply isolator / DCS input directly. This shielding is insulated from the transmitter housing. The shielding of the power supply cable and the shielding of the sensor connection cable must not be connected to one another. Make sure that the shielding is not connected to ground anywhere else.

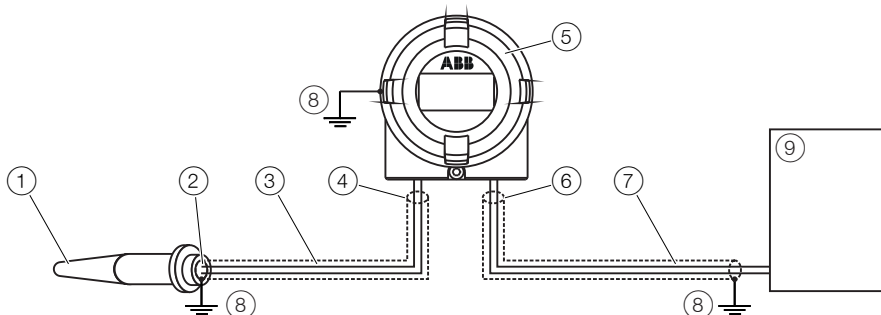

- |  |  |
|--|--|
| ① Temperature sensor                           | ⑥ Shielding insulated from transmitter housing |
| ② Shielding grounded via sensor                | ⑦ Supply voltage cable                         |
| ③ Sensor connection cable                      | ⑧ Grounding point                              |
| ④ Shielding insulated from transmitter housing | ⑨ Supply isolator / DCS input                  |
| ⑤ Transmitter housing, grounded                |  |

Figure 19: The shieldings of the sensor connection cable and the supply voltage cable are separate and each grounded at one end

### Pin assignment

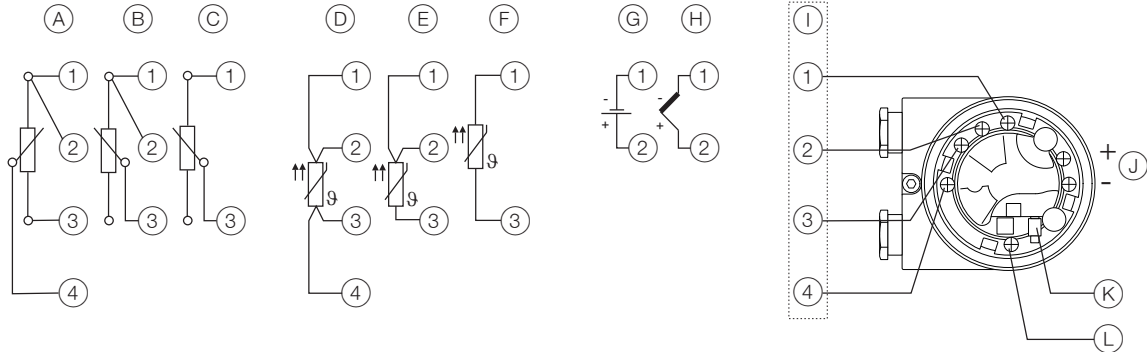

- Ⓐ Potentiometer, four-wire circuit
- Ⓑ Potentiometer, three-wire circuit
- Ⓒ Potentiometer, two-wire circuit
- Ⓓ RTD, four-wire circuit
- Ⓔ RTD, three-wire circuit
- Ⓕ RTD, two-wire circuit
- Ⓖ Voltage measurement

- Ⓗ Thermocouple
- Ⓘ Sensor terminals (of measuring inset)
- ⓵ 4 to 20 mA HART®
- Ⓚ Interface for Type BS LCD indicators
- Ⓛ Ground terminals for sensor and supply- / signal cable shielding connection

Figure 20: TTF200 terminals

## ... 7 Electrical connections

### Terminal for sensor connection cable

#### **⚠ DANGER**

**Danger of explosion if the device is operated with the transmitter housing or terminal box open!**

While using the device in potentially explosive atmospheres before opening the transmitter housing or the terminal box, note the following points:

- A valid fire permit must be present.
- Make sure that no flammable or hazardous atmospheres are present.

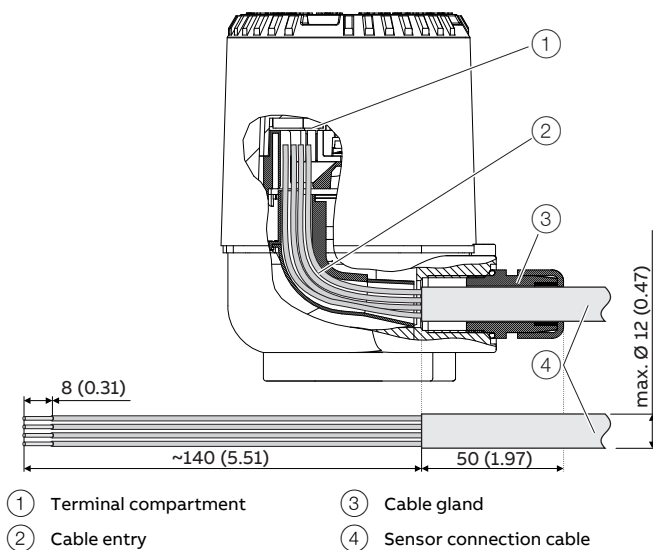

Figure 21: Connection to the transmitter, dimensions in mm (in.)

1. Tighten the lock screw under the housing cover.
2. Unscrew the housing cover.
3. If available, pull out the LCD indicator carefully
4. Strip the sensor connection cable as shown and attach wire end sleeves.  
A line length of 190 mm should be ensured between the cable gland entry and the terminals. 140 mm should be stripped from the cable jacket along this length.
5. Guide the sensor connection cable through the cable glands and into the housing. Then tighten the cable glands.
6. Connect the wires as per the connection diagram.
7. If there is one, carefully insert the LCD indicator in the previous / required position.
8. Screw the housing cover back on.
9. Loosen the lock screw until the housing cover is firmly in place.

### Electrical data for inputs and outputs

#### Input - resistance thermometer / resistances

##### Resistance thermometer

- Pt100 in accordance with IEC 60751, JIS C1604, MIL-T-24388
- Ni in accordance with DIN 43760
- Cu in accordance with recommendation OIML R 84

##### Resistance measurement

- 0 to 500  $\Omega$
- 0 to 5000  $\Omega$

##### Sensor connection type

Two-, three-, four-wire circuit

##### Connection lead

- Maximum sensor line resistance per line 50  $\Omega$  in accordance with NE 89
- Three-wire circuit:  
Symmetrical sensor line resistances
- Two-wire circuit:  
Compensation up to 100  $\Omega$  total lead resistance

##### Measurement current

< 300  $\mu$ A

##### Sensor short circuit

< 5  $\Omega$  (for resistance thermometer)

##### Sensor wire break

- Measuring range: 0 to 500  $\Omega$  > 0.6 to 10 k $\Omega$
- Measuring range: 0 to 5  $\Omega$  > 5.3 to 10 k $\Omega$

##### Corrosion detection in accordance with NE 89

- Three-wire resistance measurement > 50  $\Omega$
- Four-wire resistance measurement > 50  $\Omega$

##### Sensor error signaling

- Resistance thermometer:  
Sensor short circuit and sensor wire break
- Linear resistance measurement:  
Sensor wire break

**Input - thermocouples / voltages****Types**

- B, E, J, K, N, R, S, T in accordance with IEC 60584
- U, L in accordance with DIN 43710
- C, D in accordance with ASTM E-988

**Voltages**

- -125 to 125 mV
- -125 to 1100 mV

**Connection lead**

- Maximum sensor line resistance:  
per line 1.5 k $\Omega$ , total 3 k $\Omega$

**Sensor wire break monitoring in accordance with NE 89**

- Pulsed with 1  $\mu$ A outside measurement interval
- Thermocouple measurement 5.3 to 10 k $\Omega$
- Voltage measurement 5.3 to 10 k $\Omega$

**Input resistance**

> 10 M $\Omega$

**Internal reference junction Pt1000, IEC 60751 Cl. B**

(no additional jumpers necessary)

**Sensor error signaling**

- Thermocouple:  
Sensor wire break
- Linear voltage measurement:  
Sensor wire break

**Output****Note**

The HART<sup>®</sup> protocol is an unsecured protocol, as such the intended application should be assessed to ensure that these protocols are suitable before implementation.

**Transmission characteristics**

- Temperature linear
- Resistance linear
- Voltage linear

**Output signal**

- Configurable 4 to 20 mA (standard)
- Configurable 20 to 4 mA  
(Dynamic range: 3.8 to 20.5 mA in accordance with NE 43)

**Simulation mode**

3.5 to 23.6 mA

**Induced current consumption**

< 3.5 mA

**Maximum output current**

23.6 mA

**Configurable error current signal**

- Overrange 22 mA (20.0 to 23.6 mA)
- Underrange 3.6 mA (3.5 to 4.0 mA)

## ... 7 Electrical connections

### ... Electrical data for inputs and outputs

#### Power supply

Two-wire technology, polarity safe; power supply lines = signal lines

#### Note

Following calculations apply for standard applications. This should be taken into consideration when working with a higher maximum current.

#### Input terminal voltage

Non-Ex application:

$$U_S = 11 \text{ to } 42 \text{ V DC}$$

Ex applications:

$$U_S = 11 \text{ to } 30 \text{ V DC}$$

#### Maximum permissible residual ripple for input terminal voltage

During communication, this is in accordance with the HART® FSK 'Physical Layer' specification.

#### Undervoltage detection on the transmitter

If the terminal voltage on the transmitter down-scales a value of 10 V, this may lead to an output current of  $I_a \leq 3.6 \text{ mA}$ .

#### Maximum load

$$R_B = (U_S - 11 \text{ V}) / 0.022 \text{ A}$$

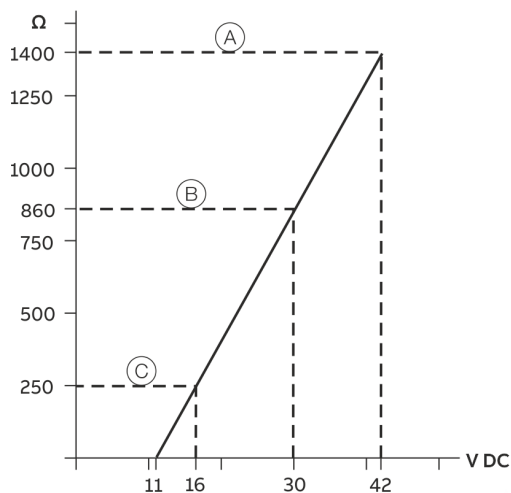

- (A) TTF200
- (B) TTF200 in Ex-applications
- (C) HART® communication resistance ( $R_B$ )

Figure 22: Maximum load depending on input terminal voltage

#### Maximum power

- $P = U_S \times 0.022 \text{ A}$
- Example:  $U_S = 24 \text{ V} \rightarrow P_{\text{max}} = 0.528 \text{ W}$

#### Voltage drop on the signal line

When connecting the devices, note the voltage drop on the signal line. The minimum supply voltage on the transmitter must not be undershot.

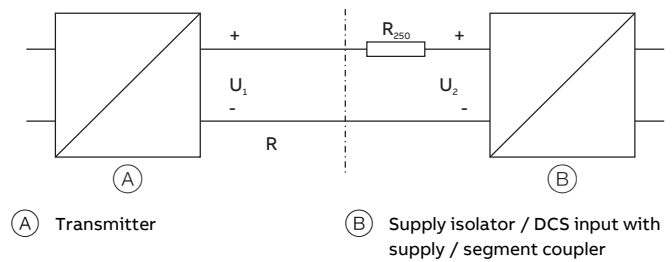

Figure 23: HART load resistance

$U_{1\text{min}}$ : Minimum supply voltage on the transmitter

$U_{2\text{min}}$ : Minimum supply voltage of the supply isolator / DCS input

R: Line resistance between transmitter and supply isolator

$R_{250}$ : Resistance (250 Ω) for HART functionality

#### Standard application with 4 to 20 mA functionality

When connecting these components, observe the following condition:

$$U_{1\text{min}} \leq U_{2\text{min}} - 22 \text{ mA} \times R$$

#### Standard application with HART functionality

Adding resistance  $R_{250}$  increases the minimum supply voltage

$$U_{2\text{min}}: U_{1\text{min}} \leq U_{2\text{min}} - 22 \text{ mA} \times (R + R_{250})$$

For HART functionality, use supply isolators or DCS input cards with a HART mark. If this is not possible, a resistance of  $\geq 250 \Omega$  ( $< 1100 \Omega$ ) must be added to the interconnection.

The signal line can be operated with / without grounding. When establishing a ground connection (minus side), make sure that only one side of the terminal is connected to the equipotential bonding.



## 8 Commissioning

### General

In case of corresponding order the transmitter is ready for operation after mounting and installation of the connections. The parameters are set at the factory. The connected lines must be checked for firm seating. Only firmly seated lines ensure full functionality.

### Checks prior to commissioning

The following points must be checked before commissioning the device:

- Correct wiring in accordance with **Electrical connections** on page 17.
- The ambient conditions must correspond to the information given on the name plate and in the data sheet.

### Communication

#### Note

The HART® protocol is an unsecured protocol, as such the intended application should be assessed to ensure that these protocols are suitable before implementation.

Communication with the transmitter takes place using the HART protocol. The communication signal is modulated onto both wires of the signal line in accordance with the HART FSK 'Physical Layer' specification.

The HART modem is connected at the signal line of the current output via which power is also supplied via the power supply unit.

The device is listed with the FieldComm Group.

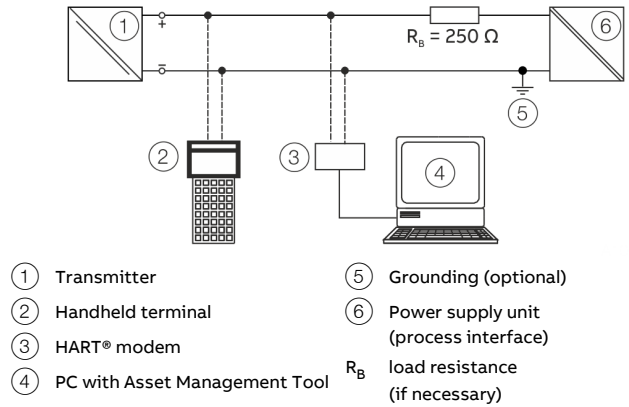

Figure 24: Example for HART connection

Manufacturer ID	0x1A
Device Type ID	0x0D
Profile	HART® 5.1
Configuration	DTM, EDD, FDI (FIM)
Transmission signal	BELL Standard 202

#### Operating modes

- Point-to-point communication mode – standard (general address 0)
- Multidrop mode (addressing 1 to 15)
- Burst Mode

#### Diagnosis notice

- Overrange / underrange in accordance with NE 43
- HART® diagnosis

## ... 8 Commissioning

### Parameterization of the device

**Note**

The device does not have operating elements for parameterization on site.

Parameterization takes place via the HART interface.

Parameterization of the device takes place via standard HART® tools. These include:

- ABB Handheld HART® Communicator DHH805 (TTX200 EDD)
- ABB Asset Vision Basic (TTX200 DTM)
- ABB 800xA Control system (TTX200 DTM)
- ABB Field Information Manager / FIM (TTX200 EDD, TTX200 Package)
- Other tools supporting standard HART® EDDs or DTMs (FDT1.2)

**Note**

Not all tools and frame applications support DTMs or EDDs at the same level. In particular, optional or advanced EDD / DTM functions may potentially not be available on all tools.

ABB provides frame applications supporting the full range of functions and performance.

## Parameter descriptions

DTM menu path, parameters	Description
<b>&lt;Device&gt; / &lt;Extras&gt;</b>	
<Write Protection>	<p>Activates write protection for the entire device</p> <ul style="list-style-type: none"> <li>• Yes: locked, entry combination: ≠ 0110</li> <li>• No: unlocked, entry combination: 0110</li> </ul>
<Device reset>	<p>Configuration data is reset to factory settings (see <b>Factory settings</b> on page 29).</p>
<Factory reset>	<p>Configuration data is reset to factory settings (see <b>Factory settings</b> on page 29).</p> <p>In addition, the adjustment data and DAC adjustment values are also reset to factory settings.</p> <ul style="list-style-type: none"> <li>• Yes / OK</li> </ul>
<b>&lt;Device&gt; / &lt;Configuration&gt;</b>	
<Sensor / Sensor type>	<p>Selects sensor type:</p> <ul style="list-style-type: none"> <li>• Pt100 (IEC751)</li> <li>• Pt1000 (IEC751)</li> <li>• Thermocouple type K (IEC584)</li> <li>• Thermocouple type B (IEC584)</li> <li>• Thermocouple type C (ASTME988)</li> <li>• Thermocouple type D (ASTME988)</li> <li>• Thermocouple type E (IEC584)</li> <li>• Thermocouple type J (IEC584)</li> <li>• Thermocouple type N (IEC584)</li> <li>• Thermocouple type R (IEC584)</li> <li>• Thermocouple type S (IEC584)</li> <li>• Thermocouple type T (IEC584)</li> <li>• Thermocouple type L (DIN43710)</li> <li>• Thermocouple type U (DIN43710)</li> <li>• Thermal voltage -125 to 125 mV</li> <li>• Thermal voltage -125 to 1100 mV</li> <li>• Resistance 0 to 500 Ω</li> <li>• Resistance 0 to 5000 Ω</li> <li>• Pt10 (IEC751)</li> <li>• Pt50 (IEC751)</li> <li>• Pt200 (IEC751)</li> <li>• Pt500 (IEC751)</li> <li>• Pt10 (JIS1604)</li> <li>• Pt50 (JIS1604)</li> <li>• Pt100 (JIS1604)</li> <li>• Pt200 (JIS1604)</li> <li>• Pt10 (IMIL24388)</li> <li>• Pt50 (IMIL24388)</li> <li>• Pt100 (MIL24388)</li> <li>• Pt200 (MIL24388)</li> <li>• Pt1000 (MIL24388)</li> <li>• Ni50 (DIN43760)</li> <li>• Ni100 (DIN43760)</li> <li>• Ni120 (DIN43760)</li> <li>• Ni1000 (DIN43760)</li> <li>• Cu10 (OIML R 84), a=4270</li> <li>• Cu100 (OIML R 84), a=4270</li> </ul>
<Sensor / Connection>	<p>Sensor connection type relevant for all Pt, Ni, Cu resistance thermometers</p> <ul style="list-style-type: none"> <li>• Two-wire: sensor connection type in two-wire technology</li> <li>• Three-wire: sensor connection type in three-wire technology</li> <li>• Four-wire: sensor connection type in four-wire technology</li> </ul>
<Sensor / Line resistance>	<p>Sensor line resistance relevant for all Pt, Ni, Cu resistance thermometers with a two-wire circuit</p> <p>Value range: 0 to 100 Ω</p>

## ... 8 Commissioning

### ... Parameterization of the device

DTM menu path, parameters	Description
<b>&lt;Device&gt; / &lt;Configuration&gt;</b>	
<Sensor / Reference junction>	<ul style="list-style-type: none"> <li>Internal: use of the internal reference junction of the transmitter when using a thermocouple / compensating cable (relevant for all thermocouples except for type B)</li> <li>External - fixed: transfer of thermal cable / compensating cable via copper material at constant thermostat temperature</li> <li>Without: no reference junction</li> </ul>
<Sensor / Reference junction temperature>	Relevant for external reference junction, specification of constant external reference junction temperature Value range: -50 to 100 °C
<b>&lt;Device &gt; / &lt;Parameterize&gt;</b>	
<Measuring range of PV / unit>	Selects the physical unit for the sensor measuring signal Units: °C, °F, °R, K, mV, Ω, mA
<Measuring range of PV / lower range value>	Defines the value for 4 mA (adjustable)
<Measuring range of PV / upper range value>	Defines the value for 20 mA (adjustable)
<Current output / damping>	Configurable $\tau$ 63% output signal damping value Value range: 0 to 100 s
<Current output / output upon error (overrange)>	Generates a high alarm signal in the event of a sensor or device error; can be configured 20 to 23.6 mA <ul style="list-style-type: none"> <li>Standard 22 mA</li> </ul>
<Current output / output upon error (underrange)>	Generates a low alarm signal in the event of a sensor or device error; can be configured 3.5 to 4 mA
<b>&lt;Device&gt; / &lt;Maintenance&gt;</b>	
<Poll address / TAG> (HART TAG)	Defines the HART TAG name. <ul style="list-style-type: none"> <li>8 characters, alphanumeric</li> </ul>
<Poll address / TAG> (Address (Multidrop))	Specifies the communication type <ul style="list-style-type: none"> <li>Address = 0 conforms to HART operating mode: point-to-point communication, 4 to 20 mA output signal</li> <li>Address = 1 to 15 conforms to HART multidrop operating mode output signal 3.6 mA, only the digital HART measured values are available</li> </ul>
<Adjustment> (Set lower range value)	Temperature correction for specified / simulated sensor lower range value to target lower range temperature value <ul style="list-style-type: none"> <li>Set Trim low or lower range value &gt; OK</li> </ul>
<Adjustment /DAC adjustment fixed for zero at 4 mA>	Output signal correction for specified / simulated sensor LRV value to 4.000 mA set point <ul style="list-style-type: none"> <li>Analog current measurement value input 3.5 to 4.5 mA</li> </ul>
<Adjustment /DAC adjustment fixed for amplification at 20 mA>	Output signal correction for specified / simulated sensor URV value to 20.000 mA set point <ul style="list-style-type: none"> <li>Analog current measurement value input 19.5 to 20.5 mA</li> </ul>
<b>&lt;Device&gt; &lt;Simulation&gt;</b>	Output signal simulation corresponding to the value specified <ul style="list-style-type: none"> <li>Value range: 3.5 to 23.6 mA</li> </ul>

### Factory settings

The transmitter is configured at the factory. The table below contains the relevant parameter values.

Menu	Designation	Parameter	Factory setting
Device Setup	Write protection	-	No
	Input	Sensor Type	Pt100 (IEC60751)
		R-Connection	Three-wire circuit
		Measured Range Begin	0
		Measured Range End	100
		Engineering Unit	Degrees C
		Damping	Off
Process Alarm		Fault signaling	Overrange 22 mA

## ... 8 Commissioning

### Basic Setup

#### Sensor error adjustment (DTM adjustment function)

Sensor error adjustment can be performed in the DTM by navigating to the menu path Device / Calibration. For sensor error adjustment, the sensor connected to the transmitter must be brought to the lower range value temperature / Trim low using a water quench or oven. It is important to make sure the temperature is balanced and stable.

In the DTM, check that the proper adjustment temperature has been entered for the sensor before adjusting it. Based on the comparison of the adjustment temperature entered (setpoints) with the digital temperature measured by the transmitter, which is available after linearization in the form of HART temperature information, the transmitter calculates the temperature deviation resulting from the sensor error.

During sensor adjustment (single-point adjustment), the temperature deviation calculated results in an offset shift of the linear characteristic output by the linearization module; the values of this characteristic correspond to the HART signal or are sent to the current output.

A pure sensor offset error can be corrected via the calibration function 'Set lower range value' or the adjustment function 'Trim low'.

By contrast, if the error is not a pure sensor offset error, it can only be corrected using two-point adjustment or two-point calibration.

#### D / A analog output adjustment (4 mA- and 20 mA-Trim)

D/A analog output adjustment is used to compensate for errors in the current input of the higher-level system. D/A analog output adjustment for the transmitter can be used to modify the loop current so that the desired value is displayed in the higher-level system.

Error compensation for the higher-level system is possible at the lower range value with 4 mA and / or 20 mA (single-point error correction: offset or two-point error correction: offset + linear gradient).

The D / A analog output adjustment can be accessed in the DTM via the menu path Device / Calibration.

Prior to analog adjustment, it is necessary to determine the loop current values based on iterative entry of current values in simulation mode; the higher-level I/O system displays exactly 4.000 mA or the lower range limit temperature, and 20.000 mA or the upper range limit temperature. The current loop values must be measured using an ammeter and recorded.

The lower range limit value or 4.000 mA should then be simulated in D / A analog output compensation mode using sensor simulation. Following this, the iteratively calculated current value at which the higher-level system displays exactly 4.000 mA or the lower range limit value must be entered as an adjustment value. Proceed in a similar manner for the upper range value or 20.000 mA.

After this correction, the AD converter error of the higher-level system is corrected by the DA converter of the transmitter. For the higher-level system, the value of the analog 4 to 20 mA output signal and the digital HART signal now match.

The adjustment should be repeated when connecting the transmitter to another input of a higher-level system.

### HART variables

The transmitter provides three HART variables. The HART variables are assigned the following values:

- Primary HART variable: process value  
The primary HART variable is assigned permanently to the analog output and is accordingly mapped to the 4 to 20 mA signal.
- Secondary HART variable: electronic unit temperature
- Third-level HART variable: electric input

### Communication / HART TAG / device addressing

For ease of identification, each HART device features a configurable 8-digit HART TAG. All devices are supplied with the HART TAG 'TI XXX' as standard. When storing HART TAG measuring point tags with more than 8 digits in the device, use the 'Report' parameter, which supports up to 32 characters.

In addition to the HART TAG, each device has a HART address. This address is set to 0 by default, which means that the device operates in HART standard communication mode (point-to-point operation).

When an address in the range 1 to 15 is used, the device switches to the 'HART Multidrop mode'.

This operating mode enables users to connect up to 15 devices to a power supply unit in parallel.

In multidrop mode, an analog output signal that matches the process temperature is not available.

The output signal in multidrop mode is a constant 3.6 mA and is used exclusively for the power supply. In multidrop mode, sensor or process data information is available only as a HART signal.

## 9 Operation

### Safety instructions

If there is a chance that safe operation is no longer possible, take the device out of operation and secure it against unintended startup.

### Process display

#### Note

The device does not have operating elements for parameterization on site.

Parameterization takes place via the HART interface.

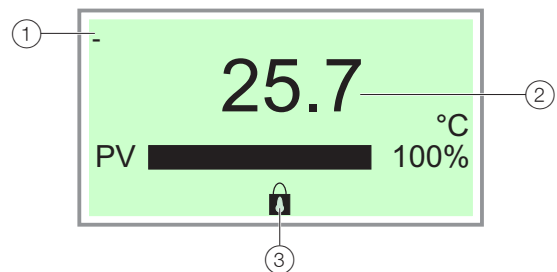

- ① Measuring point tagging (Device TAG)
- ② Current process values
- ③ 'Parameterization protected' symbol

Figure 25: Process display (example)

The process display appears on the LCD display when the device is powered on. It shows information about the device and current process values.

## ... 9 Operation

### ... Process display

#### Error messages on the LCD display

If the event of an error, a message consisting of a symbol or letter (device status) and a number (DIAG NO.) will appear at the bottom of the process display.

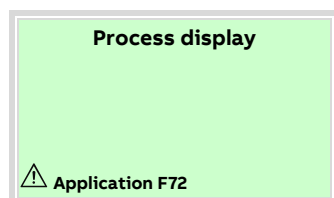

The diagnostic messages are divided into the following groups in accordance with the NAMUR classification scheme:

ID code	Description
I	<b>OK or Information</b> Device is functioning or information is available
C	<b>Check Function</b> Device is undergoing maintenance (for example simulation)
S	<b>Off Specification</b> Device or measuring point is being operated outside of the specifications
M	<b>Maintenance Required</b> Request service to prevent the measuring point from failing
F	<b>Failure</b> Error; measuring point has failed

Additionally, the diagnostic messages are divided into the following areas:

Range	Description
Electronics	Diagnosis for device hardware.
Sensor	Diagnosis for sensor elements and connection lines.
Installation / Configuration	Diagnosis for communication interface and parameterization / configuration
Operating conditions	Diagnosis for ambient and process conditions.

#### Note

For a detailed description of errors and troubleshooting instructions, please see **Diagnosis / error messages** on page 32.

## 10 Diagnosis / error messages

The transmitter signals messages and errors in different ways.

### Messages via the HART interface

The transmitter signals changed configuration or parameter setting by setting the HART flag 'Configuration-changed' (Configuration-changed).

The message can be acknowledged via the HART-DTM.

### Error message on the LCD display

In the event of an error, a message appears at the bottom of the process display, consisting of a symbol or letters (Device Status) and a number (DIAG.NO.).

See chapter **Error messages on the LCD display** on page 32.

### Error message on the current output

Sensor or device errors can be indicated by underranging or overranging of the current output.

Configuration is made via the DTM parameter '<Current output / output with error>'.



## Possible error messages – HART®

Range	Displays the device status	Displays the DIAG. NO.	Cause	Remedy
Electronics	F	1	Device defective	Replace the device
Electronics	S	2	Ambient temperature overshoot / undershot	Check environment; reposition measuring point if required
Electronics	F	3	EEPROM defective	Replace the device
Electronics	M	4	Electronics overload	Factory reset
Electronics	F	5	Memory error	Factory reset
Electronics	I	7	LCD indicator connected	Status info; not an error
Installation / Configuration	I	8	Device write-protected	Status info; not an error
Electronics	I	9	EEPROM busy	Status info; not an error
Electronics	F	12	Sensor input defective (communication)	Replace the device
Electronics	F	13	Sensor input defective (error)	Replace the device
Electronics	F	14	Sensor input defective (ADC error)	Replace the device
Installation / Configuration	C	32	Diagnostics simulation mode	Not an error, diagnostic info, measurement OK
Sensor	F	34	Measuring error, sensor	Check sensor connection
Sensor	F	35	Short-circuit, sensor	Check sensor connection
Sensor	F	36	Wire break, sensor	Check sensor connection
Sensor	F	37	Range overshoot, sensor	Check measuring limits
Sensor	F	38	Range undershot, sensor	Check measuring limits
Installation / Configuration	I	41	Single-point adjustment active, sensor	Status info; not an error
Installation / Configuration	I	42	Two-point adjustment active, sensor	Status info; not an error
Installation / Configuration	F	65	Configuration defective	Check configuration: <ul style="list-style-type: none"> <li>• Incorrect device</li> <li>• Measuring span is too small</li> <li>• Incorrect configuration data</li> </ul>
Installation / Configuration	C	71	Reconfiguration is running	Status info; not an error
Operating conditions	F	72	Error in the application	Check configuration, connections; reset to factory settings
Installation / Configuration	I	74	Analog output adjustment active	Status info; not an error
Installation / Configuration	C	75	Analog output in simulation	Status info; not an error
Operating conditions	S	76	Values overshoot	Check parameters: <ul style="list-style-type: none"> <li>• Sensor limits up-scaled</li> <li>• Measuring span is too small</li> </ul>

### Note

If the remedial measures listed for the error message do not improve the status of the device, please consult ABB Service.

## 11 Maintenance

Repair and maintenance activities may only be performed by authorized customer service personnel.  
When replacing or repairing individual components, use original spare parts.

### Safety instructions

#### DANGER

##### Explosion hazard

Explosion hazard due to improper repair of the device.

- Faulty devices may not be repaired by the operator.
- Any repair may only be performed in the production plant or by workshops authorized by ABB.

If transmitters are used as intended under normal operating conditions, no maintenance is required.

On-site repair of the transmitter or exchange of electronic components is not permissible.

### Cleaning

When cleaning the exterior of meters, make sure that the cleaning agent used does not corrode the housing surface and the gaskets.

When using the device in potentially explosive atmospheres, observe the notice on cleaning in **Protection against electrostatic discharges** on page 12.

## 12 Repair

### Safety instructions

#### DANGER

##### Explosion hazard

Explosion hazard due to improper repair of the device. Faulty devices must not be repaired by the operator.

- Any repair may only be performed in the production plant or by workshops authorized by ABB.
- Repairs on flameproof joints are not permitted.

Repair and maintenance activities may only be performed by authorized customer service personnel.

When replacing or repairing individual components, use original spare parts.

### Returning devices

Use the original packaging or a secure transport container of an appropriate type if you need to return the device for repair or recalibration purposes.

Fill out the return form (see **Return form** on page 36) and include this with the device.

In accordance with the EU Directive governing hazardous materials, the owner of hazardous waste is responsible for its disposal or must observe the following regulations for shipping purposes:

All devices delivered to ABB must be free from any hazardous materials (acids, alkalis, solvents, etc.).

Please contact Customer Center Service acc. to page 4 for nearest service location.

## 13 Recycling and disposal

### Note



Products that are marked with the adjacent symbol may **not** be disposed of as unsorted municipal waste (domestic waste). They should be disposed of through separate collection of electric and electronic devices.

This product and its packaging are manufactured from materials that can be recycled by specialist recycling companies.

Bear the following points in mind when disposing of them:

- As of 8/15/2018, this product will be under the open scope of the WEEE Directive 2012/19/EU and relevant national laws (for example, ElektroG - Electrical Equipment Act - in Germany).
- The product must be supplied to a specialist recycling company. Do not use municipal waste collection points. These may be used for privately used products only in accordance with WEEE Directive 2012/19/EU.
- If there is no possibility to dispose of the old equipment properly, our Service can take care of its pick-up and disposal for a fee.

## 14 Specification

### Note

The device data sheet is available in the ABB download area at [www.abb.com/temperature](http://www.abb.com/temperature).

## 15 Additional documents

### Note

Declarations of conformity of the device are available in the download area of ABB at [www.abb.com/temperature](http://www.abb.com/temperature). In addition, these are also included with the device in case of ATEX-certified devices.

## 16 Appendix

### Return form

#### Statement on the contamination of devices and components

Repair and/or maintenance work will only be performed on devices and components if a statement form has been completed and submitted.

Otherwise, the device/component returned may be rejected. This statement form may only be completed and signed by authorized specialist personnel employed by the operator.

#### Customer details:

Company: \_\_\_\_\_

Address: \_\_\_\_\_

Contact person: \_\_\_\_\_

Telephone: \_\_\_\_\_

Fax: \_\_\_\_\_

Email: \_\_\_\_\_

#### Device details:

Type: \_\_\_\_\_

Serial no.: \_\_\_\_\_

Reason for the return/description of the defect: \_\_\_\_\_

#### Was this device used in conjunction with substances which pose a threat or risk to health?

Yes

No

If yes, which type of contamination (please place an X next to the applicable items):

biological

corrosive / irritating

combustible (highly / extremely combustible)

toxic

explosive

other toxic substances

radioactive

Which substances have come into contact with the device?

1. \_\_\_\_\_

2. \_\_\_\_\_

3. \_\_\_\_\_

We hereby state that the devices/components shipped have been cleaned and are free from any dangerous or poisonous substances.

\_\_\_\_\_  
Town/city, date

\_\_\_\_\_  
Signature and company stamp

## Trademarks

HART is a registered trademark of FieldComm Group, Austin, Texas, USA

## Notes

## Notes



—  
**ABB Limited**

**Measurement & Analytics**

Howard Road, St. Neots  
Cambridgeshire, PE19 8EU  
UK

Tel: +44 (0)870 600 6122

Fax: +44 (0)1480 213 339

Email: [enquiries.mp.uk@gb.abb.com](mailto:enquiries.mp.uk@gb.abb.com)

**ABB Inc.**

**Measurement & Analytics**

125 E. Count Line Road  
Warminster, PA 18974  
USA

Tel: +1 215 674 6000

Fax: +1 215 674 7183

**ABB Automation Products GmbH**

**Measurement & Analytics**

Schillerstr. 72  
32425 Minden  
German

Tel: +49 571 830-0

Fax: +49 571 830-1806

[abb.com/temperature](http://abb.com/temperature)

—  
We reserve the right to make technical changes or modify the contents of this document without prior notice. With regard to purchase orders, the agreed particulars shall prevail. ABB does not accept any responsibility whatsoever for potential errors or possible lack of information in this document.

We reserve all rights in this document and in the subject matter and illustrations contained therein. Any reproduction, disclosure to third parties or utilization of its contents – in whole or in parts – is forbidden without prior written consent of ABB.