

Operating instruction

IM/264IB_1

FieldIT

2600T Series

Model 264IB

Multivariable Field Indicator

FOUNDATION Fieldbus version

IndustrialIT
enabled



ABB

The Company

We are an established world force in the design and manufacture of instrumentation for industrial process control, flow measurement, gas and liquid analysis and environmental applications.

As a part of ABB, a world leader in process automation technology, we offer customers application expertise, service and support worldwide.

We are committed to teamwork, high quality manufacturing, advanced technology and unrivalled service and support.

The quality, accuracy and performance of the Company's products result from over 100 years experience, combined with a continuous program of innovative design and development to incorporate the latest technology.

The NAMAS Calibration Laboratory No. 0255(B) is just one of the ten flow calibration plants operated by the Company, and is indicative of our dedication to quality and accuracy.

EN ISO 9001: 1994



Cert. No. Q5907

EN ISO 9001: 2000



Cert. No. 9/90A



Cert. No. 0255

Use of Instructions



Warning.

An instruction that draws attention to the risk of injury or death.



Note.

Clarification of an instruction or additional information.



Caution.

An instruction that draws attention to the risk of damage to the product, process or surroundings.



Information.

Further reference for more detailed information or technical details.

Although **Warning** hazards are related to personal injury, and **Caution** hazards are associated with equipment or property damage, it must be understood that operation of damaged equipment could, under certain operational conditions, result in degraded process system performance leading to personal injury or death. Therefore, comply fully with all **Warning** and **Caution** notices.

Information in this manual is intended only to assist our customers in the efficient operation of our equipment. Use of this manual for any other purpose is specifically prohibited and its contents are not to be reproduced in full or part without prior approval of Technical Communications Department, ABB.

Health and Safety

To ensure that our products are safe and without risk to health, the following points must be noted:

1. The relevant sections of these instructions must be read carefully before proceeding.
2. Warning labels on containers and packages must be observed.
3. Installation, operation, maintenance and servicing must only be carried out by suitably trained personnel and in accordance with the information given. Any deviation from these instructions, will transfer the complete liability to the user.
4. Normal safety precautions must be taken to avoid the possibility of an accident occurring when operating in conditions of high pressure and/or temperature.
5. Chemicals must be stored away from heat, protected from temperature extremes and powders kept dry. Normal safe handling procedures must be used.
6. When disposing of chemicals ensure that no two chemicals are mixed.

Safety advice concerning the use of the equipment described in this manual or any relevant hazard data sheets (where applicable) may be obtained from the Company address on the back cover, together with servicing and spares information.

INDEX:

Acronyms.....	4
Preamble.....	4
Foundation Fieldbus Definition.....	4
1. Introduction.....	5
1.1. Transport.....	5
1.2. Storage.....	5
1.3. Handling.....	5
1.4. Product Identification.....	5
2. Device Introduction.....	5
2.1. General Considerations.....	5
2.1.1. Field Indicator.....	5
2.1.2. Control Function Block Controller.....	6
2.1.3. LAS Backup Capability.....	6
2.2. FF Version Considerations.....	6
2.3. FF Registration Details.....	7
3. Hardware Characteristics.....	8
3.1. Environmental Protections.....	8
3.2. Fault Protection.....	9
3.3. Hardware Settings.....	9
3.4. Local Display.....	9
3.5. Electrical Connection.....	10
3.6. Installation.....	14
4. 264IB used as Field Indicator.....	15
4.1. Configuration of the 264IB to be used as Field Indicator.....	17
4.1.1. Designing of the Function Block Application.....	17
4.1.2. Commissioning and Configuration.....	17
5. 264IB used as Function Block Container.....	18
5.1. EPID Algorithm.....	19
5.2. Arithmetic Algorithm.....	21
5.3. Input Selector Algorithm.....	24
5.4. Control Selector Algorithm.....	25
6. Examples of Control Strategies.....	26
7. 264IB used as LAS Backup Device.....	30
8. Network Architecture.....	32
9. FOUNDATION Fieldbus Overview.....	34
10. Device Addressing.....	35
11. Device Configuration.....	35
Resource Block.....	36
EPID Function Block.....	38
Arithmetic Function Block.....	40
Input Selector Function Block.....	42
Control Selector Function Block.....	43
MUX Function Block.....	44
Display Transducer Block.....	45
12. Operating Modes.....	46
13. Diagnostic.....	46
13.1. Alarm Summary.....	47
13.2. Alarm Priority.....	47
13.3. Block Error.....	48
13.4. Troubleshooting.....	52
13.5. Status Supported.....	55
14. Device Specifications Data.....	56
15. Reference.....	56
APPENDIX A - Electronic Replacement.....	57

IMPORTANT NOTE !!!!

The FF Drivers specific of the 264IB revision 1 described in this manual are the following:

0101.ffo	DD Object File
0101.sym	DD Symbol File
010101.cff	Capability File

Before to use this 264IB revision in communication with any Fieldbus Host, check that the above FF drivers (DD & CFF) have been previously installed.

Future 264IB revisions will be always released with the specific FF drivers.

In case the Fieldbus Host has already installed the FF drivers of the old 264IB revision, it is necessary to install the new FF drivers for the support of the new 264IB revision.

In this way old and new revisions of the same device type can work together with the same Host

ACRONYMS

- LCD	- Liquid Crystal Display
- RB	- Resource Block
- EPID	- Enhanced Proportional Integral Derivative Block
- AR	- ARithmetic Block
- IS	- Input Selector Block
- CS	- Control Selector Block
- MUX	- MultipleXer Block
- TB	- Display Transducer Block
- AI	- Analog Input
- AO	- Analog Output
- LAS	- Link Active Scheduler
- FBAP	- Function Block Application
- DD	- Device Description
- CFF	- Capability File Format
- H1	- Low Speed Fieldbus Segment
- FF	- Foundation Fieldbus
- IS	- Intrinsically Safety
- FISCO	- Fieldbus IS Concept
- OOS	- Out Of Service

Preamble

In order to make easier the description, all the variables mentioned in this document are written with the suffix RB or MUX or TB or EPID or AR or IS or CS indicating the block into where the variables are mapped.

Foundation Fieldbus Definition

FOUNDATION™ Fieldbus is an all-digital, serial, two-way communication system that serves as a Local Area Network (LAN) for factory/plant instrumentation and control devices.

FOUNDATION™ Fieldbus is designed to be compatible with the officially sanctioned SP50 standards project of the ISA (The International Society for Measurement and Control) and the specifications of the IEC (International Electrotechnical Committee)

A unique characteristic of FOUNDATION™ Fieldbus is interoperability that ensures its use of a fully specified, standard User Layer based on “Blocks” and Device Description technology.

Detailed information of the Foundation Fieldbus is available from the site (www.fieldbus.org) and/or from the ABB site (www.abb.com)

1.- Introduction

1.1 - Transport

After final calibration, the instrument is packed in a carton (Type 2 to ANSI/ASME N45.2.2-1978), intended to provide protection from physical damage.

1.2 - Storage

The instrument does not require any special treatment if stored as despatched and within the specified ambient conditions level (Type 2 to ANSI/ASME N45.2.2-1978).

There is no limit to the storage period, although the terms of guarantee remain as agreed with the Company and as given in the order acknowledgement.

1.3 - Handling

The instrument does not require any special precautions during handling although normal good practice should be observed.

1.4 - Product identification

The instrument is identified by the data plates shown in Figure 1.

The Nameplate (ref.A) provides information concerning the code number, power supply and output signal. See code/specification sheet for detailed information. This plate also shows the transmitter serial number.

Please refer to this number when making enquiries.

A Safety Marking plate (ref. B) is fitted when the transmitter is required to comply with hazardous area regulations, e.g. flameproof, intrinsic safety or both protection type combined.

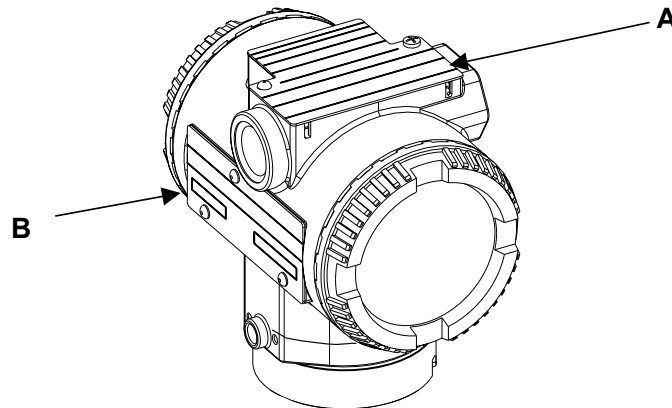

2. – Device Introduction

2.1 – General Considerations

The Multivariable Field Indicator is an accessory device of the 2600T Series. It communicates with any Host supporting the FOUNDATION™ Fieldbus protocol.

The 2600T-264IB has been designed for implementing different functions for different purposes:

2.1.1-Field Indicator.

The 264IB can be used as Field Indicator for up to 8 variables available on the H1 segment and 1 variable produced by the Host.

The 8 H1 variables to be monitored on the display are selected during the design of the Function Block Application and linked in input at the MUX Function Block. This block has up to 9 inputs and is specific for the usage of the 264IB as Field Indicator.

Any single variable to be displayed is selected scrolling the TAGs on the display.

The scrolling is executed acting through the two external keys.

2.1.2-Control Function Block Container.

The 264IB can be used as Control Function Blocks container in order to improve the control strategies whenever the transmitters connected on the segment do not allow it.

The 264IB Revision 1 implements the following Control Function Blocks:

- 1 Standard Arithmetic Block
- 1 Standard Input Selector Block
- 1 Standard Control Selector Block
- 2 Enhanced Proportional Integral Derivative Function Block.

In this way the 264IB appears as an universal resources container to support specific requirements for different kind of applications (cascade control, flow compensation)

2.1.3-LAS Backup Capability.

The 264IB can be configured as the LAS backup device of the H1 segment in order to maintain alive the control loop whenever the primary LAS element, typically the controller, fails. This features, implemented on a dedicate unit like the 264IB, provides enhanced security both for the transmitters which perform basically the measurement task and for the LAS function itself performed without using resources assigned to the measure.

The 264IB is covered by multiple agency safety approvals (including ATEX-FISCO and FM) supported by intrinsically safe and explosion proof designs, for a full compliance to hazardous area requirements.

2.2 – FOUNDATION™ Fieldbus Version Considerations

The 2600T-264IB Foundation Fieldbus Revision 1 implements and is compliant to the communication Protocol FOUNDATION™ Fieldbus specification version 1.5.

The 2600T-264IB FF Revision 1 is registered as a Link Master Device and implements the following functionality:

- **Client/Server VCR.**
This communication type is used for the operator messages like read/write of configurations or maintenance data. This is a not scheduled message but executed when the operator requires it.
- **Publisher/subscriber VCR.**
This communication type is used for Process Control purpose. These are the scheduled and cyclic exchange of data.
- **Report/Distribution VCR.**
This communication type is used when the slave device has to advise the operator consoles about the occurrence of alarms (Event Notification) or for Trend report.
- **LAS Functionality.**
With this functionality the 264IB FF can acts as backup master, keeping alive the Function block application whenever the Primary LAS in Master/Controller fails.
The LAS implemented in the device supports 1 sub-schedule, 96 sequences and 25 elements for sequence.
- **1 Enhanced Resource Block**
This block identifies the transmitter and includes characteristics of the instrument connected at the fieldbus like Model, Serial Number, Manufacturer and so on. Only 1 Resource Block can be present in each device.
- **1 Custom Multiplexer Block**
This block is specifically implemented for the usage of the 264IB as Field Indicator. It has up to 9 inputs where the selected variables must be linked-in and one output to the Display Transducer Block
- **1 Custom Display Transducer Block**
This block receives in input from the Multiplexer Block the variable to be displayed
- **1 Arithmetic Block**
- **1 Input Selector Block**
- **1 Control Selector Block**
- **2 Enhanced Proportional Integral Derivative Function Block.**
Inside the Function blocks are contained the information/parameters relating the Process Control. Each Function Block type provides specific functionality.
The combination of the different Function Blocks contained in the 264IB with Function Blocks residing into other devices of the Bus, offer the possibility to design more complete control strategies in the field.
- **FMS services supported:**
 - Initiate / Abort / Status / Identify / Read Variable / Write Variable / Get Object Dictionary

- **Link objects mechanism.**
This allows the linking between the produced Values or Alarms or Trends in output from the Function Blocks (Publisher) with other Input Blocks enabled to receive these information (Subscriber).
- **Event Notification mechanism.**
This provides to automatically send an alarm message to the Master whenever an alarm or event condition occurs. This message includes details about when the event occurred (date, time) and about the reason of the event or alarm (subcode).
- **Trend Objects.**
These objects collect a defined number of sampling of a selected variable, under different conditions.

2.3 – Registration Details
DEVICE

Model:	2600T Series– Models 2641B
Type:	Multivariable Field Indicator
Revision:	1.0
Tested Function Blocks:	2xPID(e), 1xAR(c), 1xIS(c), 1xRB(e)
Other Blocks:	1xTB DISPLAY (Custom), 1xMUX(Custom), 1xCS(c)
Comm. Profile Class:	31PS, 32L
IT Campaign Number:	IT0025500

PHYSICAL LAYER
Class: 111, 113, 511

DEVICE DESCRIPTION
Manufacturer ID Num: 0x00320
Device Type: 0x0006
DD Revision: 1.0

CAPABILITY FILE
Filename: 010101.cff



FIELDBUS FOUNDATION CERTIFICATE



FIELDBUS FOUNDATION

DEVICE

REGISTRATION

Presented To: ABB SACE SpA
 Model: 2600T Series - Model 2641B
 Device Type: Multivariable Field Indicator
 ITK_Ver: 4.51
 IT Campaign Number: IT025500
 Registration Date: 5/11/2004
 DD Revision: 0x01
 CFF Revision: 010101.cff

The above device has successfully completed rigorous testing by the Fieldbus Foundation and has received registration and the right to use the FF checkmark logo as specified by MT-045.

 Heather Cannard
 Test Technician

 Richard J. Timoney
 President





3. – Hardware Characteristics

3.1 – Environmental Protection

The 264IB FF is an integrated electronic designed for IS application. The 264IB is compliant and conforms to the Entity and FISCO certifications.

TYPE PLATE AND CERTIFICATION LABELS

SERIAL NUMBER		CE 1130 Made in Italy Year 2003		FIELD TERMINALS
MWP OVP	SPAN LIMITS			
URL	OUTPUT SIGNAL	Foundation Fieldbus - IEC 1158-2		
LRL	POWER SUPPLY	9 - 32 VDC		
PRODUCT CODE				
		IP67		



FOUNDATION™
2600T SERIES Pressure Transmitter
 **ABB SACE S.p.A.**
Lenno-Co-Italia
 Local keys below label

FOUNDATION™ Fieldbus Type Plate

ABB SACE S.p.A. Lenno (Co) Italy	2600 T SERIES 264 IB Field Indicator	CE 0722
EEx ia II 1 GD T50°C EEx ia IIC T6 resp. II 1 GD T95°C EEx ia IIC T4		
<input type="checkbox"/> For the electrical parameters see the certificate [FISCO Model]		
<input type="checkbox"/> EEx d II 2 GD EEx d IIC T6 T85°C (-40°C < Ta < +75°C)		
Power Supply : 42 Vd.c. / 2 W max		
IP 67	ZELM 04 ATEX 0216 X	Ex

EUROPE CERTIFICATION LABEL

Agency: ATEX / ZELM
Certificate N°: EC-Type Examination Certificate n° ZELM 04 ATEX 0216X

" FACTORY SEALED" ○	ENCL.4X T.AMB.=85°C MAX	
EXPLOSIONPROOF: CLASS I, DIV.1, GROUPS A,B,C,D DUST IGNITIONPROOF: CLASS II, DIV.1, GROUPS E,F,G SUITABLE FOR: CL.II, DIV.2, GR.F,G, CL.III, DIV.1,2 NONINCENDIVE: CLASS I, DIV.2, GROUPS A,B,C,D (SEE DRAWING DH 3045) INTRINSICALLY SAFE (ENTITY): CL.I, DIV.1, GR.A,B,C,D, CL.II, DIV.1, GR.E,F,G CL.III, DIV.1 WHEN CONNECTED PER CONTROL DRAWING DH 3045 INTRINSIC SAFETY CL.I, ZONE 0, AEx ia IIC T6,T5,T4 For wiring and entity parameters see Drawing DH 3045		
○	 APPROVED	○

" FACTORY SEALED" ○	ENCL.4X T.AMB.=85°C MAX	
EXPLOSIONPROOF: CLASS I, DIV.1, GROUPS A,B,C,D DUST IGNITIONPROOF: CLASS II, DIV.1, GROUPS E,F,G SUITABLE FOR: CL.II, DIV.2, GR.F,G, CL.III, DIV.1,2 NONINCENDIVE: CLASS I, DIV.2, GROUPS A,B,C,D (SEE DRAWING DH 3045) INTRINSICALLY SAFE (ENTITY): CL.I, DIV.1, GR.A,B,C,D, CL.II, DIV.1, GR.E,F,G CL.III, DIV.1 WHEN CONNECTED PER CONTROL DRAWING DH 3045 INTRINSIC SAFETY CL.I, ZONE 0, AEx ia IIC T6,T5,T4 For wiring and entity parameters see Drawing DH 3045		
○		○

NORTH AMERICA CERTIFICATION LABEL

Agency: FM - CSA
Protection Type: Intrinsically safe: Class I, II, III, Div.1, Groups A, B, C, D, E, F, G
 Explosionproof: Class I, Div.1, Groups A, B, C, D
 Dust Initiationproof: Class II, Div.1, Groups E, F, G
 Suitable for: Class II, Div.2, Groups F, G; Class III, Div.1, 2
 Nonincendive: Class I Div.2, Groups A, B, C, D
 Intrinsic safety: Class I, Zone 0, AExia IIC T6, T5, T4

3.2 – Fault Protection

This electronic implements also an especial circuitry for the fault current protection. Whenever a fatal failure occurs and the current consumption increase over the 20 mA, this circuitry provides to disconnect the device from the bus, in order to save the good functionality of the other connected devices that otherwise would be switched off due to the missing power available.

3.3 – Hardware Settings

On the electronic unit (behind the Local Display when installed) there are 4 DIP switches, see the Figure 1, with the following functionality:

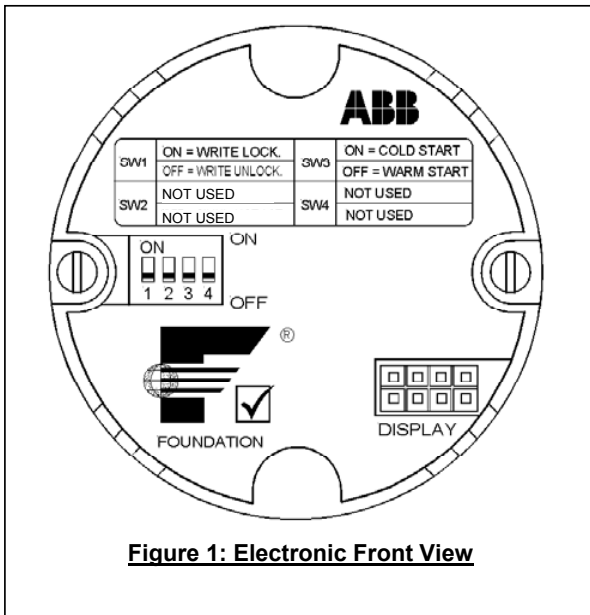

Figure 1: Electronic Front View

SW 1 - Write Locking:

In ON position enables the Write Locking condition. The attempts to change the configuration of the device are refused.

The SW1 in ON position enable the Write Locking only if the "HW Write Lock Supported" bit is set in the RB_FEATURE_SEL, see the Resource Block table in section 11 – Device Configuration

SW 2 not used: (For future use)

SW 3 - Cold Start:

In ON position enables the Cold Start-up. A Cold Start-up feature is available in order to initialise all the parameters requiring a well-defined value, with the default values. This operation can be performed setting the Cold Start-up switch 3 in the ON position before to power on the device, many variables of the MUX and TB are properly set with default values

SW 4 not used: (For future use)

3.4 – Local Display

The display of the 264IB is a Dot matrix type with one 5 digit line for the displaying of Values, one 7 characters alphanumeric line for the displaying of Strings, plus a 50 segments bar-graph. In this way it is possible display the variable's Value and Status, Engineering Unit and TAG.

There are two options for the selection of how display the variables:

- 1- Acting on the external push buttons, see the Figure 4. The choice of the variable to be displayed is executed scrolling the TAGs of the max.9 variables available in input (8 linked and 1 from the Host) and selecting the desired one.
- 2- Selecting the automatic scrolling of the linked variables. The MUX_SEQUENCE variable can be configured just for enable/disable such functionality. When enabled, the MUX_IN_SELECT will be incremented every 10 seconds scrolling only the input of the MUX block linked with other Function Block outputs.



Figure 2: Integral Local Display

Details about how to configure and use the 264IB as Field Indicator are described in the section 4.

3.5 – Electrical Connection

The 264IB FF is a Bus Powered device with FOUNDATION™ Fieldbus output. On the terminal block there are two screws for the BUS CONNECTION, see the Figure 3.

☞ The Polarity has not consistency. The two bus cables can be connected without take care of the polarity.

Figure 3: Terminal Block

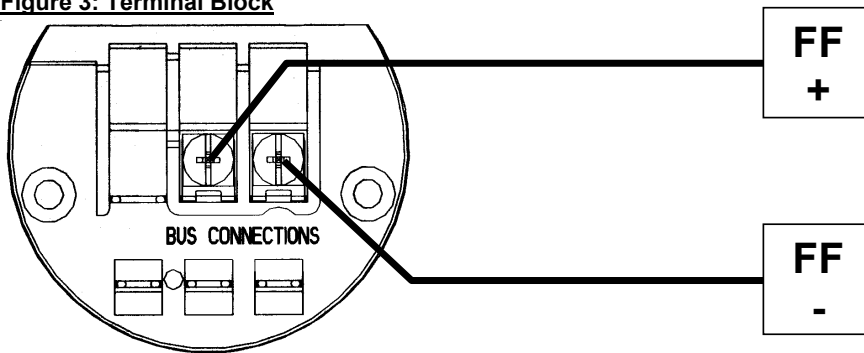

If necessary the ground terminal could be also connected. For details about the connections refer to the “*Wiring and Installation 31.25 kbit/s, Voltage Mode, Wire Medium*” Application Guide document **ag-140s** and/or the “*31.25 kbit/s Intrinsically Safe System*” Application Guide document **ag-163s** available on the Fieldbus Foundation website (www.fieldbus.org)

The special Fieldbus Connector is also available as optional item for the easy connection of the transmitter to the bus. Below there are the pictures of the two selected models with different plugs.

WARNING - These connectors can be used **ONLY FOR UNCLASSIFIED LOCATION**



7/8" PLUG



M12x1 PLUG

☞ The **7/8" PLUG** model is considered the default version for the 264IB - FOUNDATION Fieldbus version.

☞ The connector Thread will be in accordance with the selected Housing Model. By default the Housing Thread is **1/2 - 14 NPT**

The picture below shows the pin-out of the two different Fieldbus connector models.

- The Bus lines are polarity independent.
- The GROUND and SHIELD connections must be evaluated depending by the installation rules

FIELDBUS Versions

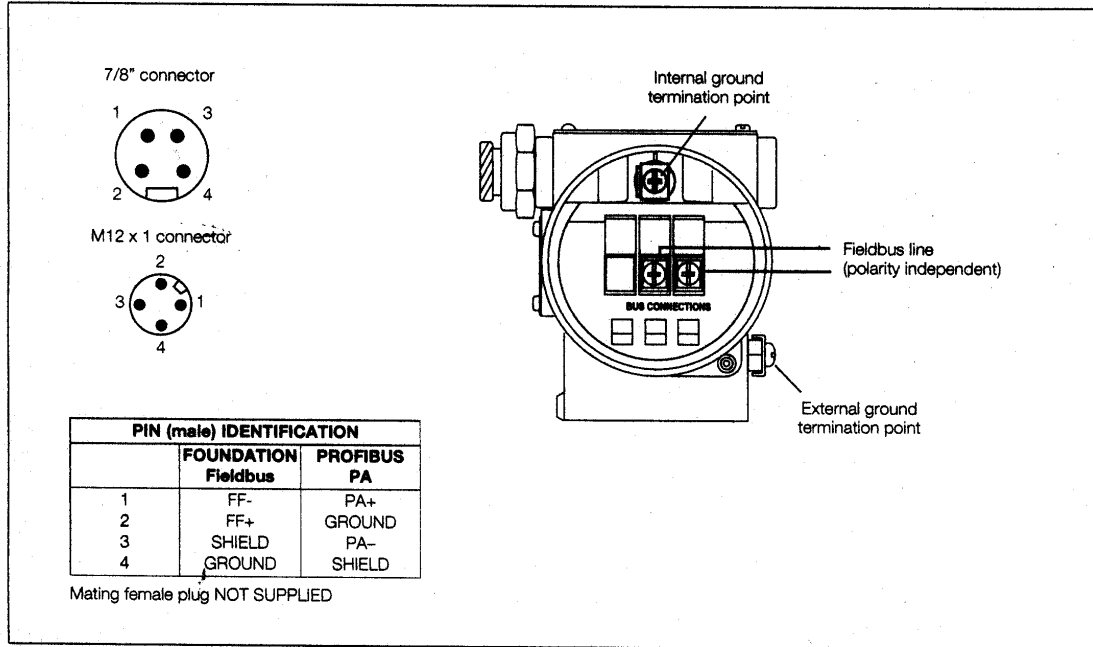

The Surge Protection is also available as optional item to be connected externally on the device's housing thread, see the picture below as example.

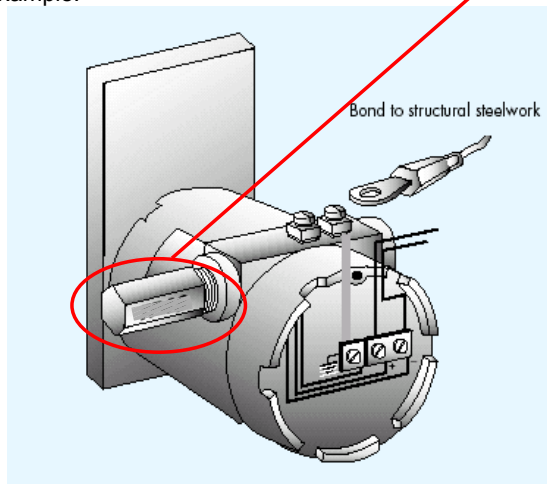

WARNING - The Surge Protection can be used **ONLY FOR UNCLASSIFIED LOCATION**

By default the threads of the housing and the relating Surge Protection is **1/2 - 14 NPT**

WARNING - For installation in Hazardous Areas, i.e. areas with danger of fire and/or explosion, prior to making electrical connections, ensure compliance with safety information on the Safety Marking plate. Failure to comply with this warning can result in fire or explosion.

Signal terminals are located in a separate compartment of the secondary unit housing. The housing incorporates two connection ports for cable glands or conduit fittings. They are protected with a temporary plastic plug for transit purpose which should be replaced with a suitable permanent plug in the unused port. Connections can be made by removing the cover (indicated in Fig. 7); first screw down the locking screw located below the cover, using a 3 mm Allen Key.

WARNING - For Hazardous Areas installations, the connection of cables and conduits to the transmitter shall be made in accordance with the requirements of the relevant type of protection. Cables and cable-glands must be in accordance with the type of protection. Unused openings for connection shall be closed with blanking elements suitable for the relevant type of protection. With the exception of intrinsically safe transmitters, the means provided for this shall be such that the blanking element can be removed only with the aid of tools. The blanking elements must be certified for the type of protection. See standards either EN 60079-14 or IEC 79-14. The unit connections must also guarantee the degree of protection of the unit enclosure, e.g. IPxx according to EN 60529 standard (or IEC529). See also the Addendum for "IP" protection (and Ex Safety) which is part of this instruction manual.

The signal cable should be connected to the terminals marked respectively (+) and (-). The power to the unit is supplied over the signal wiring and no additional wiring is required. The signal wiring does not need to be shielded but the use of a twisted pair is highly recommended. The cable shield should be grounded in one side only, to avoid dangerous earth paths.

WARNING - For Hazardous Areas installations, when the ambient temperature is higher than 70°C, the cable used for the connections must be suitable for 5°C above the ambient temperature.

Normal practice is to ground in the control room side, in which case the field side of the screen should be adequately protected to avoid contact with metallic objects. Signal wiring may be ungrounded (floating) or grounded at any place in the signal loop, but for intrinsically safe installations the wiring and grounding must follow the specific rules for this technique. The unit case may be grounded or ungrounded: a ground connection is provided internally (in the terminal compartment) and externally.

Do not run the signal wiring in close proximity to power cable or high power equipment; use dedicated conduits or trays for signal wiring.

After the connections have been completed check the integrity of the cover O-ring, screw down the cover and secure it by unscrewing the safety screw.

CAUTION - Unless absolutely necessary, avoid the removal on site of the protective cover which gives access to the electronic circuitry. Although the electronics are fully tropicalized they should not be subjected to humidity for long periods.

WARNING - For Hazardous Areas installations, at least eight (8) threads on each cover must be engaged in order for the unit to meet (flameproof - explosion-proof) requirements.

According to ATEX Directive (European Directive 94/9/EC of 23 March 1994) and relative European Standards which can assure compliance with Essential Safety Requirements, i.e., EN 50014 (General requirements) EN 50018 (Flameproof enclosures "d") EN 50020 (Intrinsic safety "i") EN 50284 (Equipments, group II, category 1G) EN 50281 (Apparatus for use with combustible dusts), the 2641B has been certified for the following group, categories, media of dangerous atmosphere, temperature classes, types of protection.

Note for device with ATEX combined approval

WARNING - Before installation of the device, the customer should permanent mark his choice Protection Concept on the safety label. The device can only be used with according to this Protection Concept for the whole life. The selected Type of Protection is allowed to be changed only by manufacturer after a new satisfactory assessment.

Certificate ATEX II 1GD T50°C, EEx ia IIC T6 (-40°C ≤ Ta ≤ +40°C)
respectively, II 1GD T95°C, EEx ia IIC T4 (-40°C ≤ Ta ≤ +85°C)

and ATEX II 2 GD, EEx d IIC T6
IP67 T85°C (-40°C ≤ Ta ≤ +75°C)

ZELM certificate number ZELM 04 ATEX 0216 X (X = Special conditions for safe use)

For special conditions for safe use see certificate

The meaning of ATEX code is as follows:

- II : Group for surface areas (not mines)
- 1 or 2 : Category
- G : Gas (dangerous media)
- D : Dust (dangerous media)
- T50°C: Maximum surface temperature of the transmitter enclosure with a Ta (ambient temperature) +40°C for Dust (not Gas) with a dust layer up to 50 mm depth.
- T95°C: As before for Dust for a Ta +85°C

and for Flameproof protection type:

- T85°C: Maximum surface temperature of the transmitter enclosure with a Ta (ambient temperature) +75°C for Dust (not Gas) with a dust layer up to 50 mm depth.

(Note: the number close to the CE marking of the transmitter safety label identifies the Notified Body which has responsibility for the surveillance of the production)

The other marking refers to the Intrinsic safety protection type used according to relevant EN standards:

- EEx ia : Intrinsic safety, protection level "a"
- IIC : Gas group
- T6 : Temperature class of the transmitter (which corresponds to 85°C max) with a Ta (ambient temperature) +40°C
- T4 : Temperature class of the transmitter (which corresponds to 135°C max) with a Ta (ambient temperature) +85°C

The other marking refers to the Flameproof protection type used according to relevant EN standards:

- EEx d: Flameproof
- IIC : Gas group
- T6 : Temperature class of the transmitter (which corresponds to 85°C max) with a Ta (ambient temperature) +75°C.

3.6 – Installation

WARNING - In order to ensure operator safety and plant safety it is essential that installation is carried out by suitably trained personnel according to the technical data provided in the specification for the relevant model.

The 264IB Indicator may be mounted on a 2-inch pipe (see following figures) by means of the proper mounting bracket

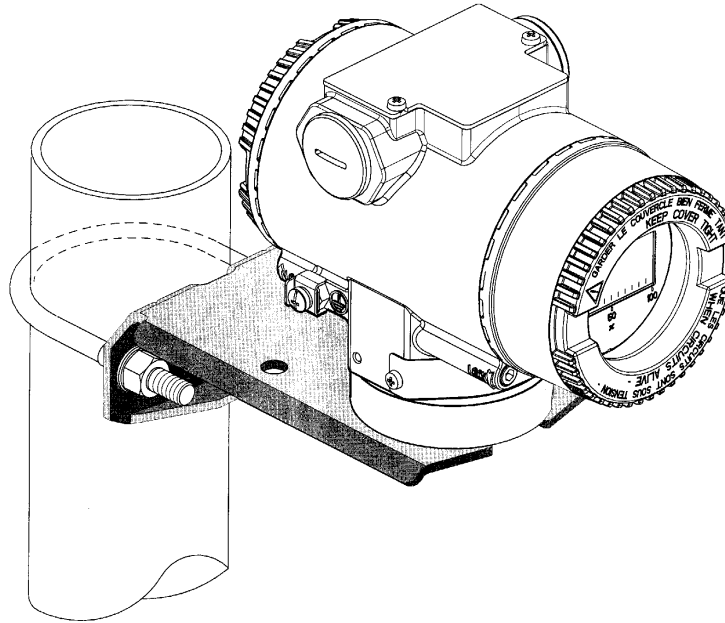

WARNING - For installation in Hazardous Areas, i.e. areas with dangerous concentrations of e.g. gases or dusts that may explode if ignited, the installation must be carried out in accordance with relative standards either EN 60079-14 or IEC 79-14 and/or with local authority regulations, for the relevant type of protection adopted.

WARNING: The indicator when installed in accordance with this instruction manual will not be subjected to mechanical stresses.

WARNING: the indicator should not be installed where it may be subjected to mechanical and thermal stresses or where it may be attached by existing or foreseeable aggressive substances.

The housing of the indicator may be rotated of 360° approx. without any damage use the 2 mm Allen key supplied to unlock and lock the tang grub screw. This feature, obtained by unscrewing (one turn is sufficient) the Allen screw, is particularly useful for reaching optimum access to the electrical connections and visibility of the output indicator.

4. – 264IB used as Field Indicator

When the 264IB works as Field Indicator, the Value of the selected variable is displayed on the first 5 digits line. The second line of 7 alphanumeric characters alternating displays the Engineering units of the variable, its Status and TAG.

The **Status** byte is always transmitted together with the Variable's **Value** and is displayed as GOOD or UNCERT or BAD.

The Engineering Unit and TAG are not transmitted with the publisher/subscriber communication and for this reason they have to be preliminary set for each linked input of the MUX Block during the 264IB configuration/commissioning, see the section 4.1.2.

The MUX Block provides, for any of the 9 input variables, an associated Unit Code and TAG to be set in order to have on the display a complete information about the specific selected variable, see the Display Block.

Such kind of configuration can be performed through all the DD based configuration tool.

Once the 9 (or less) variables linked in input to the MUX block have been properly set with their associated Unit Code and TAG, and the Function Block Application has been downloaded into all the devices on the segment, it is possible to proceed selecting the variable to be displayed.

By default no input is selected (MUX_IN_SELECT = 0) and on the display will appear the string:

OUT OF SERVICE

Then after the two external push buttons have been kept pressed together for **more than 2 seconds**, see the figure 4, it will be displayed the string:

SEQUENC ON?

At this stage the user has two possible actions:

1. Pressing again the two push buttons for more than 2 seconds, the user enables the automatic scrolling of the active inputs (linked in).

The confirmation that the sequence has been enabled comes from the string:

PROG OK

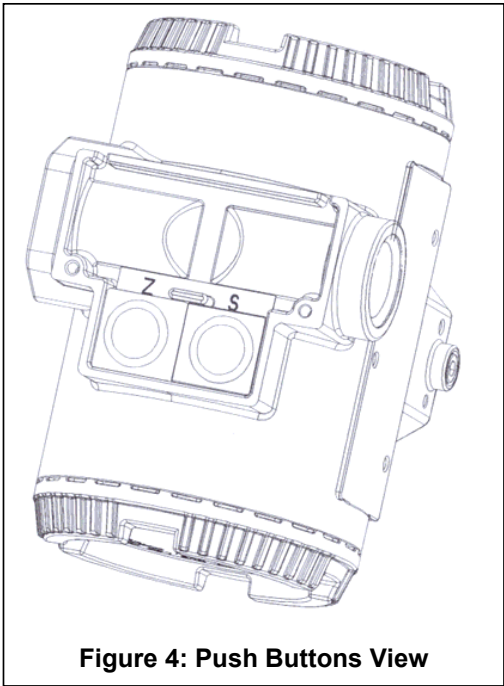

Figure 4: Push Buttons View

The same condition can be enabled writing from the host into the MUX_SEQUENCE parameter selecting the automatic scrolling. In this case only the active/linked inputs are selected every 10 seconds and displayed. Before to switch on the next active input, it will be displayed the following strings for 2 seconds:

**NEXT
xxxxxx**

Where **xxxx** represents the TAG of the next active input.

In this way the user can preliminary realize that the display is switching on the next active input having the xxx TAG and then, the next Values, Engineering units, Status will refer to the next active input/TAG.

☞ When the Automatic Scrolling is enabled, the Input 9 (HOST_IN) is always scrolled as active input because it cannot be linked due the fact it is dedicated to the Client /Server Telegrams

2. Starting from this condition any pressing of the 'S' or 'Z' key will act respectively as 'NEXT' or 'PREVIOUS' scrolling all the TAGs previous configured and associated at the input variables.

When the desired TAG appears, the associated variable will be selected when the two external push buttons are being pressed together for **more than 2 seconds**. The confirmation of the selection is coming by the string:



☞ The selection can be performed also from the remote configuration tool writing into the MUX_IN_SELECT a value in the range between 1 and 9 representing the input variables

Immediately after get start the displaying of the Value with the Engineering Unit, Status and TAG of the new selected variable.

The refresh rate is of 1second. Every 1 second the display will show one of the different combinations on line 1 and 2 as in the example below:



☞ **Depending by the Status of the variable, in the second line will be displayed one of the following strings: **GOOD_NC** or **GOOD_C** or **UNCERT** or **BAD**

Whenever the TAG scrolling goes trough input without a valid configured TAG, the display will show a message as follow, with the Input Number and correspondent configured TAG:



☞ The TAG is invalid and produces the above displaying when the string is with all spaces/blank characters

Whenever the desired TAG is displayed, the correspondent input is selected pushing the two buttons together for more than 2 seconds. Whenever the input is not linked to a valid variable, the following message will be displayed and blinking:



The TB_KEY_ENABLE parameter is stored in the NV memory and provides to enable/disable the operation with the push button. Whenever the TB_KEY_ENABLE is set to disable, any action on the push button produces the following string on the display:



The factory default set the TB_KEY_ENABLE in “enable status”: local selection allowed.

Whenever the RB_WRITE_LOCK is set and/or the Switch 1 of the electronics is in ON position = Write Lock, see the section 3.3 – Hardware Settings, any attempt to select a different input with the push button is refused and the following string id produced on the display:



4.1 – Configuration of the 264IB to be used as Field Indicator

Whenever the 264IB must work as Field Indicator, the user has to perform some operation in order to make it working properly. Following there are some sections to be followed step by step by the user

4.1.1 – Designing of the Function Block Application

The Figure 5 is an example about how to design the FBAP using the MUX block of the 264IB for the Field Indicator function. The Outputs of different Function Blocks of different transmitters are linked in input at the MUX_IN_x in order to configure the MUX block as subscriber of the selected variables.

Figure 5:

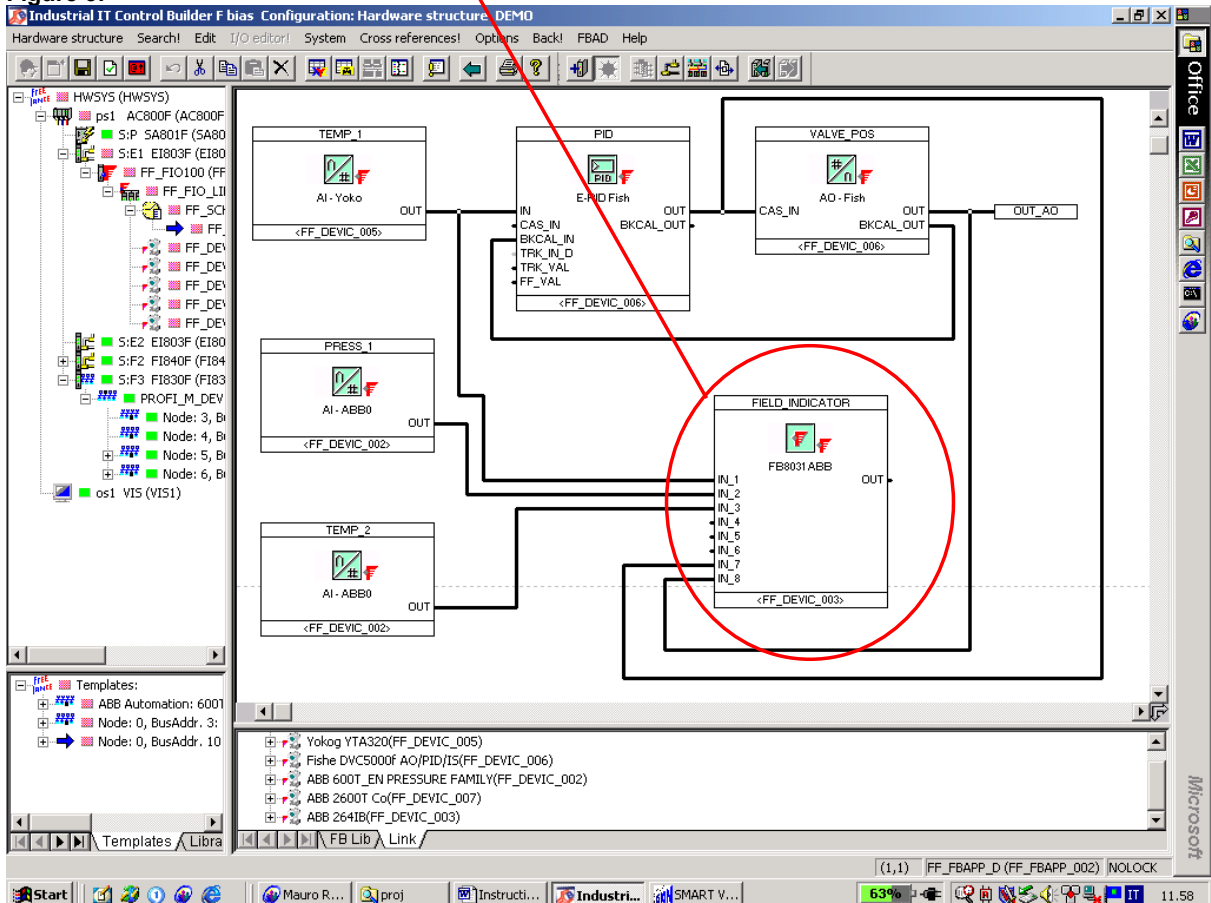

After the downloading of the FBAP into the devices, it is possible to proceed with the configuration of the 264IB used as Field Indicator.

4.1.2 – Commissioning and Configuration

Typically after the FBAP downloading the MUX block is in OUT of Service and this condition is also displayed. In order to switch the MUX block in AUTO it is necessary to follow these steps:

- 1- For each used/linked MUX_IN_x must be configured the associated TAG and Engineering Unit (MUX_IN_x_UNIT and MUX_IN_x_TAG) to be displayed together with the Value and Status received by the MUX via the Publisher/subscriber telegrams.
- 2- Remove the value 0 from the MUX_SEQUENCE and set a valid selection: Automatic Scrolling enabled or disabled.
- 3- Remove the value 0 from the MUX_IN_SELECT and set a valid value in the range 1-9 relating the input to be displayed.
- 4- Switch the TB and MUX target mode to AUTO.



The TAG can be max.16 characters long but only the first 7 characters will be displayed as allowed by the second line of the Display.

The figure 6 below shows an example about how to set the specific TAG and Engineering Unit dedicated to each active MUX input.

Figure 6:

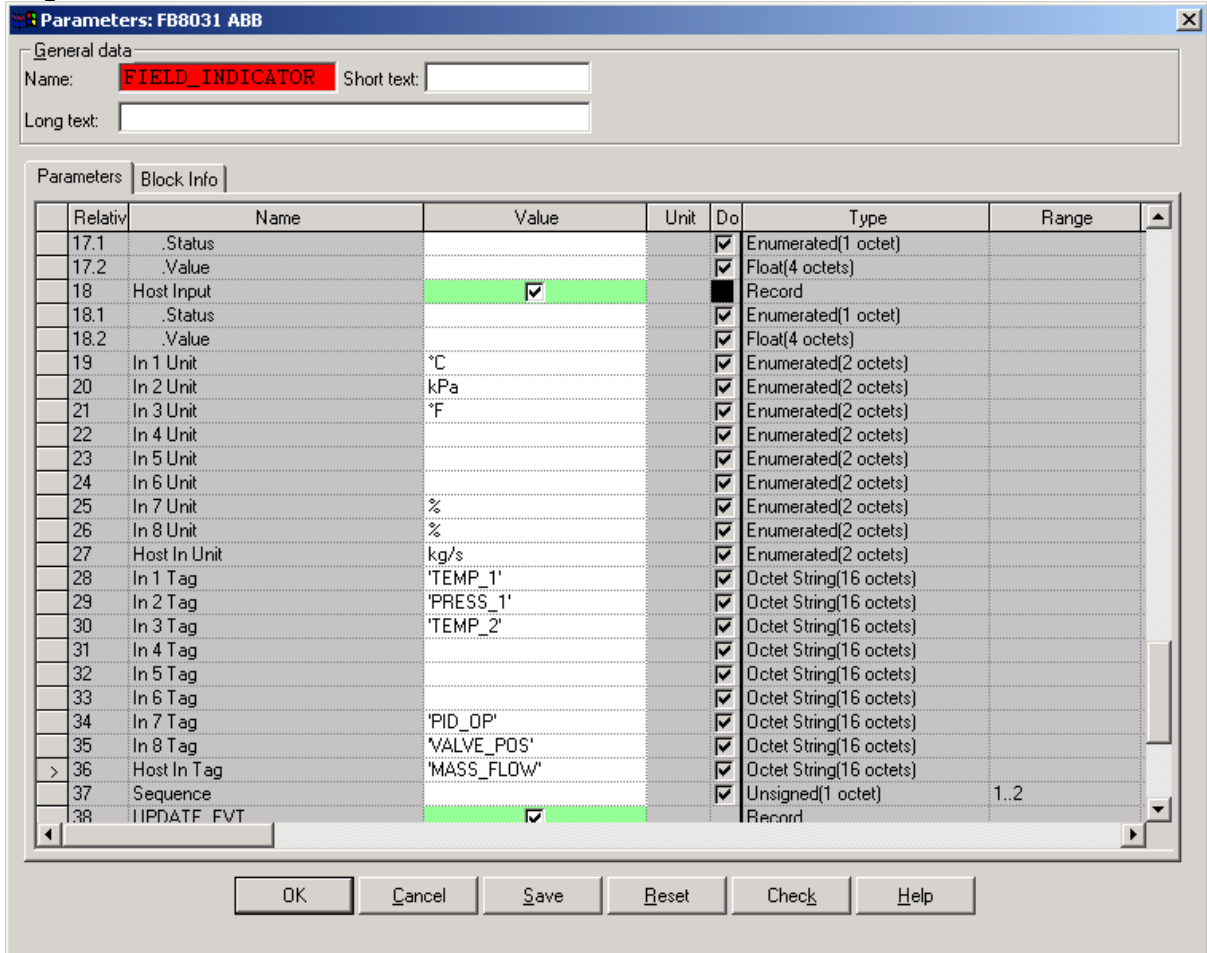

The TAGs and Units selected as in the example above will be then displayed together with the Value and Status of the correspondent Input when it will be selected.

The example shows also that the MASS_FLOW value expressed in kg/s not available as H1 variable but result of a calculation in the Controller will be displayed when its Value and Status is written from the Host into the MUX_Host_Input and the MUX_Input_Select is switched on the Input 9.

5. – 264IB used as Function Block Container

The 264IB implements some Control Function Blocks in order to increase the control strategy capability in the field when not available or supported in the transmitters connected on the H1 segment.

The list of Control Function Blocks implemented is the following:

- 1 Arithmetic Block (AR)
- 1 Input Selector Block (IS)
- 1 Control Selector Block (CS)
- 2 Enhanced Proportional Integral Derivative Function Block (EPID)

These blocks can be used for satisfy specific control strategies like Cascade Control, Hydrostatic Tank Gauge, Flow Compensation and more.

5.1 - EPID Algorithm

The EPID is available inside the 264IB. See the block diagram in the Figure 7:

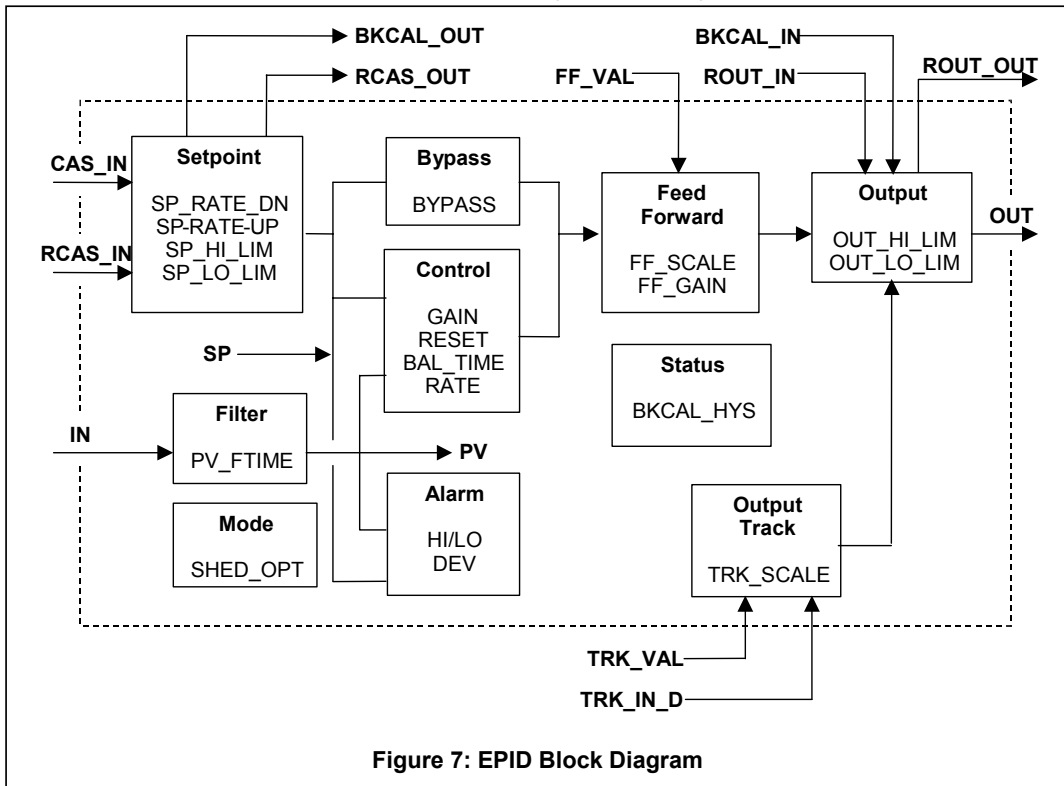

Figure 7: EPID Block Diagram

The EPID receives in input the value produced in output from another block like Analog Input, and provides to apply the algorithm with the Proportional, Integral, Derivative contribute as previously configured.

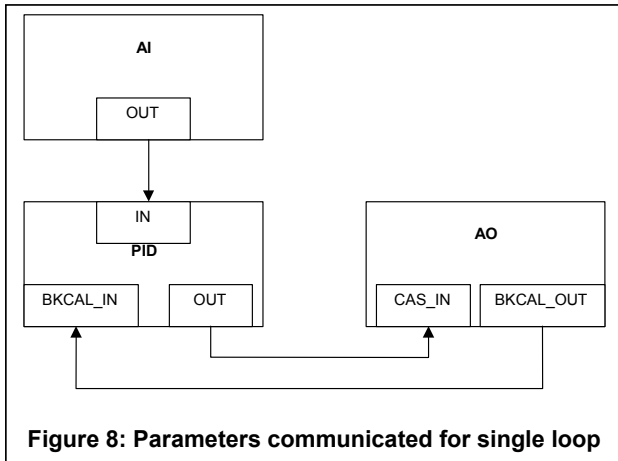

Figure 8: Parameters communicated for single loop

The algorithm applied is as in the following formula:

$$OUT = GAIN \cdot \left[(BETA \cdot SP - PV) + \frac{1}{RESET \cdot s} (SP - PV) + \frac{RATE \cdot s}{T1_RATE \cdot s + 1} (GAMMA \cdot SP - PV) \right] + FF_VAL$$

Where: GAIN: Proportional Gain Value
RESET: Integral action Time constant in seconds
s: Laplace operator
RATE: Derivative action time constant in seconds
T1_RATE: Derivative 1st order filter
BETA: Setpoint weight proportional part [0...1]
GAMMA: Setpoint weight derivative part [0...1]
FF_VAL: Feed-forward contribution from the feed-forward input
SP: Setpoint
PV: Process Variable

STATUS HANDLING:

Refer to the standard list of the Status Byte in the section 13.5.

The OUT Status can be affected by the setting of the STATUS_OPTS

5.2 – ARITHMETIC Algorithm

The Arithmetic Function Block is available inside the 264IB. See the block diagram in the Figure 9:

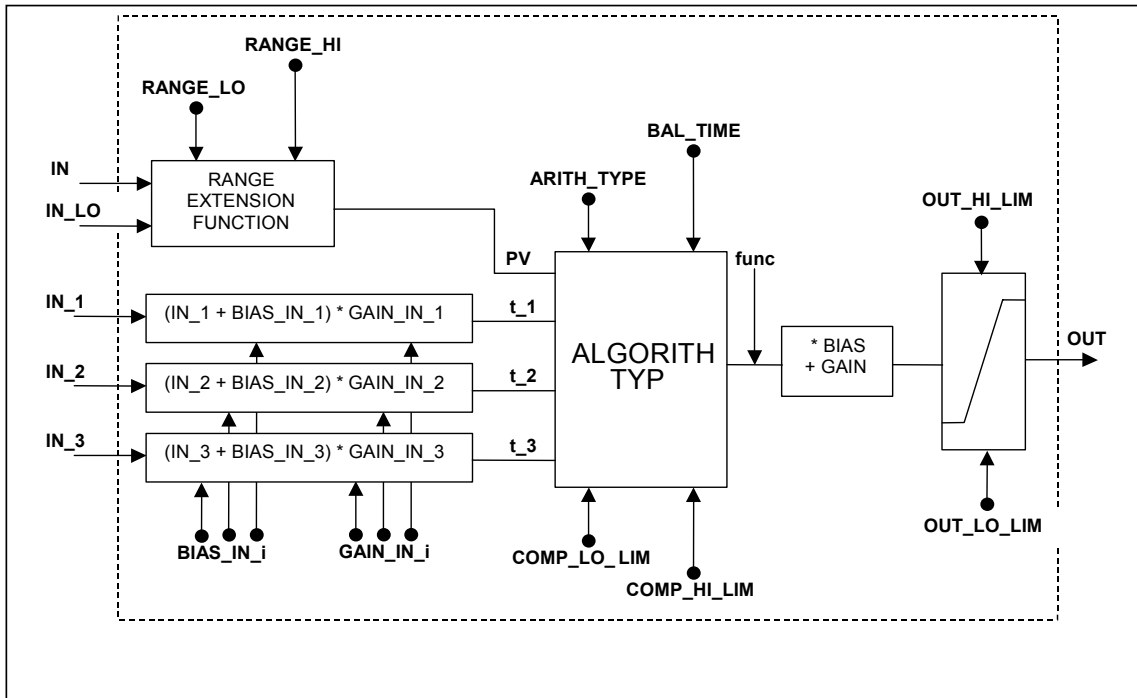

ALGORITHMS:

The IN and IN_LO are used for calculation of the PV. The PV in combination with the IN_1, IN_2 and IN_3 produces the **func** value depending by the selected compensation function (ARITH_TYPE). A **gain** is applied at the **func** and a **bias** is added for the production of the PRE_OUT. In AUTO mode the PRE_OUT is transferred to the OUT.

$$PV = G * IN + (1 - G) * IN_{LO}$$

$$G = \frac{IN - RANGE_{LO}}{RANGE_{HI} - RANGE_{LO}} \rightarrow G \text{ in a range of } 0-1 \text{ for } IN \text{ from } RANGE_{LO} \text{ to } RANGE_{HI}$$

Each input IN_1, IN_2 and IN_3 has a dedicated gain and bias. The compensation terms **t** are calculated as follow:

- For usable IN_i

$$t_i = GAIN_{IN_i} * (BIAS_{IN_i} + IN_i)$$
- For NOT usable IN_i

$$t(i) = \text{last } t(i) \text{ computed with last usable } IN_i$$

With the ARITH_TYPE it is possible select the following algorithms:

Code	Algorithm Type	Description	Function
1	Flow Compensation Linear	Used for density compensation of Volume flow	$OUT = (f * PV * GAIN + BIAS)$ <p>Where $f = \frac{t_{-1}}{t_{-2}}$ is limited</p>
2	Flow Compensation Square Root	Usually: - IN_1 is pressure → (t_1) - IN_2 is temperature → (t_2) - IN_3 is the compressibility factor Z → (t_3)	$OUT = (f * PV * GAIN + BIAS)$ <p>Where $f = \sqrt{\frac{t_{-1}}{t_{-2} * t_{-3}}}$ for Volumetric Flow is limited</p> <p>For the calculation of the Volumetric Flow $t_{-3} = Z$ The compressibility factor Z can be set writing into the IN_3 a constant value Z or can be calculated by a previous block linked in the IN_3.</p> $OUT = (f * PV * GAIN + BIAS)$ <p>Where $f = \sqrt{\frac{t_{-1} * t_{-3}}{t_{-2}}}$ for Mass Flow is limited</p> <p>In case it would be necessary produce the Mass Flow, the compressibility factor Z must be set as into the IN_3 as $\frac{1}{Z}$.</p>
3	Flow Compensation Approximate	Both IN_1 and IN_2 would be connected to the same temperature NOTE: - The Square Root of the third power can be achieved connecting the input to IN and IN_1. - The Square Root of the fifth power can be achieved connecting the input to IN, IN_1, IN_3.	$OUT = (f * PV * GAIN + BIAS)$ <p>Where $f = \sqrt{t_{-1} * t_{-2} * t_{-3}^2}$ is limited</p>
4	BTU Flow	- IN_1 is the inlet temperature - IN_2 is the outlet temperature	$OUT = (f * PV * GAIN + BIAS)$ <p>Where $f = t_{-1} - t_{-2}$ is limited</p>
5	Traditional Multiply Divide		$OUT = (f * PV * GAIN + BIAS)$ <p>Where $f = \frac{t_{-1}}{t_{-2}} + t_{-3}$ is limited</p>
6	Average		$OUT = \frac{PV + t_{-1} + t_{-2} + t_{-3}}{f} * GAIN + BIAS$ <p>f = number of inputs used in computation</p>
7	Traditional Summer		$OUT = (PV + t_{-1} + t_{-2} + t_{-3}) * GAIN + BIAS$
8	Fourth Order Polynomial	All inputs except IN_LO (not used) are linked together	$OUT = (PV + t_{-1}^2 + t_{-2}^3 + t_{-3}^4) * GAIN + BIAS$
9	Simple HTG Compensated Level	- The PV is the tank base pressure - IN_1 is the top pressure → (t_1) - IN_2 is the density correction pressure → (t_2) - GAIN is the height of the density tap	$OUT = \frac{PV - t_{-1}}{PV - t_{-2}} * GAIN + BIAS$

CONFIGURATION RULES:

1. If the selected ARITH_TYPE is in the range between 1-5 (limited functions), the output limits COMP_HI_LIM > COMP_LO_LIM
2. The BAL_TIME must be greater than the Block Execution Time
3. When the ARITH_TYPE = 6 (Average) in case of no inputs available the output will be set to NaN (Not a Number)

STATUS HANDLING:

Status of PV depends by the factor 'g'. If it is less than 0,5 it will be used the Status of IN_LO otherwise it will use the Status of IN

The inputs with status byte different by GOOD are controlled by the INPUT_OPTS. The status of unused inputs is ignored.

The Status of the OUT will be the same of PV except when the PV is GOOD and the Status of the auxiliary inputs is NOT GOOD and the INPUT_OPTS is not configured to use it. In this case the Status of the OUT is UNCERTAIN.

Otherwise the OUT Status id the worst of the inputs used in the calculation after applying the INPUT_OPTS.

Supported INPUT OPTIONS:

- IN Use uncertain
- IN LO Use uncertain
- IN_1 Use uncertain
- IN_1 Use bad
- IN_2 Use uncertain
- IN_2 Use bad
- IN_3 Use uncertain
- IN_3 Use bad

5.3 – INPUT SELECTOR Algorithm

The Input Selector Function Block is available inside the 264IB. See the block diagram in the Figure 10:

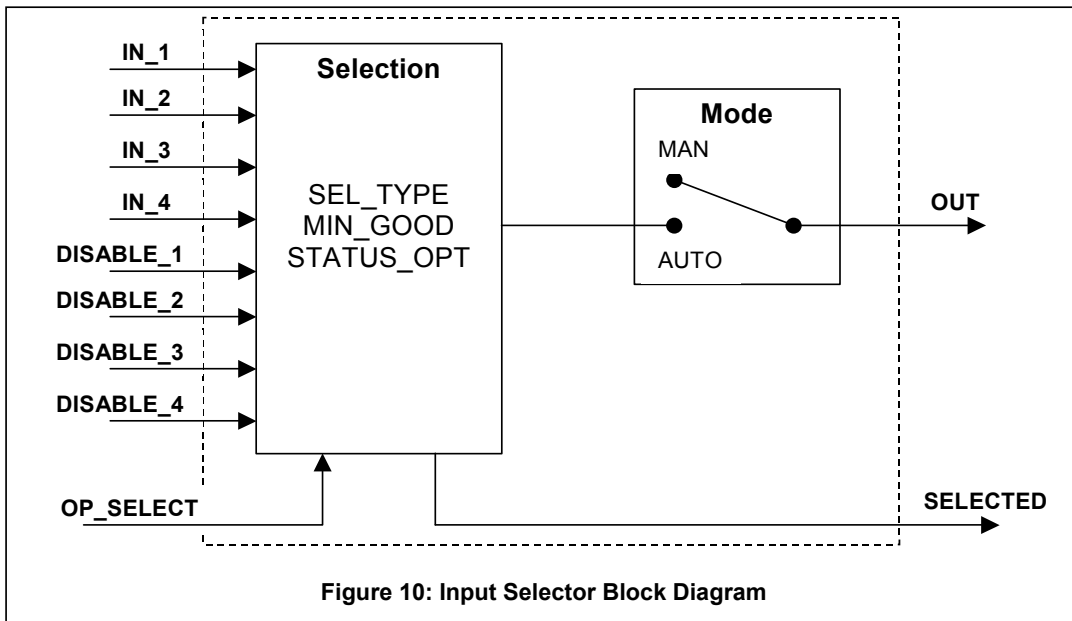

ALGORITHMS:

With the SELECT_TYPE it is possible to select the following algorithms:

1. **First Good:** Select the first available Input with Good Status
2. **Minimum:** Select the minimum value of the Inputs
3. **Maximum:** Select the maximum value of the Inputs
4. **Middle:** Calculate the middle of three inputs or the average of the two middle inputs if four inputs are defined
5. **Average:** Calculate the average value of the inputs

BASIC RULES:

If the DISABLE_x is set, the correspondent input is not used in the SEL_TYPE algorithms

If the OP_SELECT is set with a value between 1-4, the SEL_TYPE algorithm is overridden and the OUT value and status is set to the value and status of the input selected by OP_SELECT.

SELECTED will have the number of the selected input unless the SEL_TYPE is average, in which case it will have the number of the inputs used for the average.

STATUS BYTE HANDLING:

When in AUTO mode the OUT reflects the Value and Status of the selected input (IN_x).

If the number of inputs with GOOD status is less than the MIN_GOOD value, the OUT status will be BAD-Non Specific.

With the STATUS_OPTS it is possible to select the following options:

- **Use Uncertain as Good:** Set the IS_OUT status to Good when the Selected Input Status is Uncertain
- **Uncertain if Manual Mode:** The Status of the IS_OUT is set to Uncertain when the Mode is set to Manual

5.4 – CONTROL SELECTOR Algorithm

The Control Selector Function Block is available inside the 264IB. See the block diagram in the Figure 11:

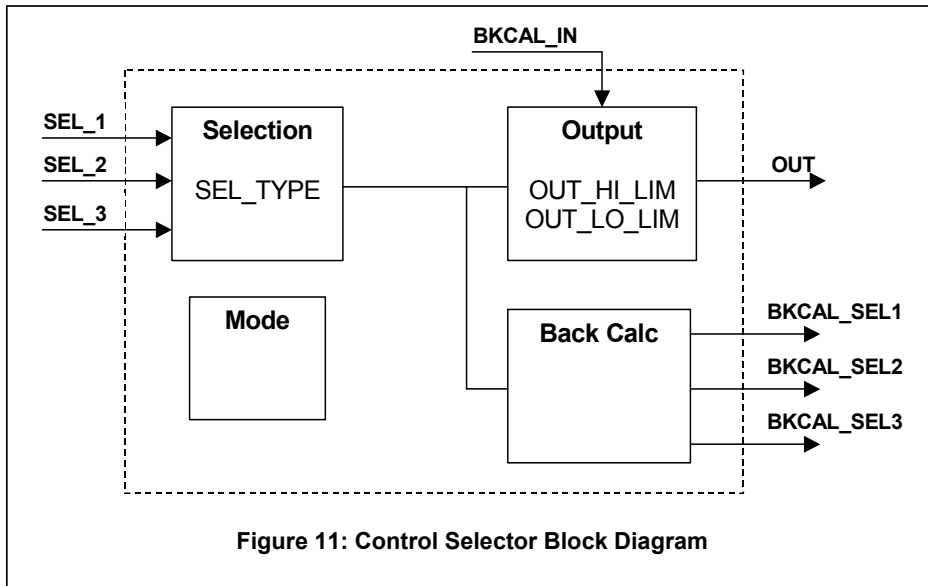

ALGORITHMS:

With the SEL_TYPE it is possible to select the following algorithms:

1. **High**
2. **Low**
3. **Middle**

BASIC RULES:

All the inputs should have the same scale of the OUT because one of them will be selected to be output.

There is a BKCAL_SEL_x output for each SEL_x input.

A specific value of the BKCAL_SEL_x status indicates those SEL_x not selected.

The value of each BKCAL_SEL_x is the same as the OUT.

For the not selected inputs, the BKCAL_SEL_x are limited to high for Low selector type, limited to low for High selector type or one for each for Middle selector type.

STATUS BYTE HANDLING:

The OUT Status of the CS block is the same as the Selected Input exception for:

- If input is Uncertain, the output is Bad unless the STATUS_OPTS is set to **Use Uncertain as Good**.
- If all the inputs are Bad the CS mode goes to MAN as well as it does the PID. This condition produces the OUT Status to be set to IFS if the STATUS_OPTS is set to **IFS if BAD IN**.
- If no inputs have been linked or are valid the OUT Status is set to Bad - Configuration Error

Supported STATUS_OPTS:

- IFS if BAD IN
- Use Uncertain as GOOD

Status supported for other output variables:

- If the BKCAL_IN status is NI or IR, this status is transferred to the three BKCAL_SEL_x
- If the BKCAL_IN status is not normal it is transferred to the selected BKCAL_SEL_x output.
- The BKCAL_SEL_x Status of the deselected inputs is set to Not Selected with the appropriate high or low limit set.
- When the CS is in MAN no inputs are selected. All the BKCAL_SEL_x status are set to Not Invited and Constant limits with the same value of OUT.

6. – Example of Control Strategies

FLOW COMPENSATION CONFIGURATION

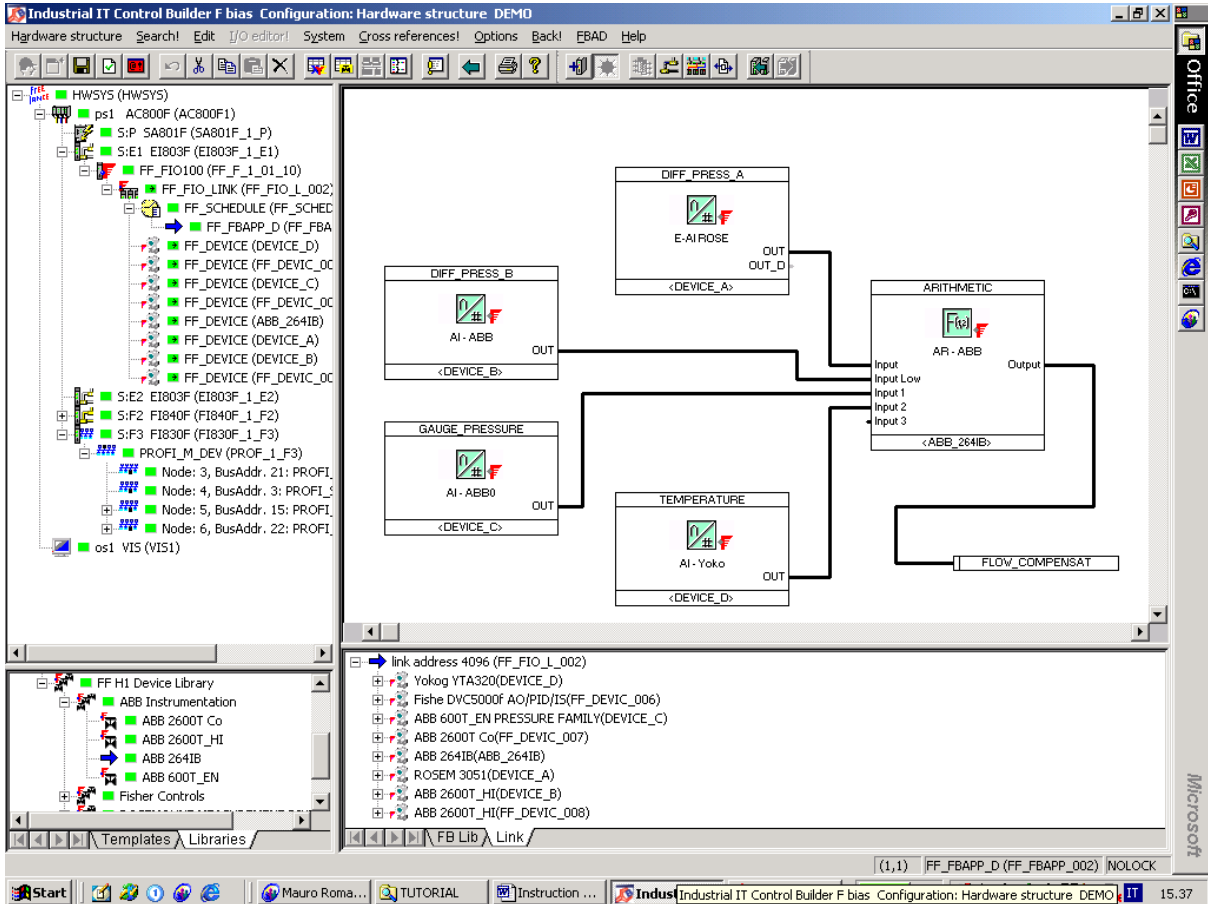

$$OUT = (G * DEVICE_A + (1 - G) * DEVICE_B) * \sqrt{\frac{DEVICE_C}{DEVICE_D * Input_3(\text{compressibility factor } Z)}} * GAIN + BIAS$$

$$G = \frac{IN - RANGE_LO}{RANGE_HI - RANGE_LO}$$

MUST BE INSERTED EXAMPLES OF APPLICATIONS WITH THE NEW FUNCTION BLOCKS

MUST BE INSERTED EXAMPLES OF APPLICATIONS WITH THE NEW FUNCTION BLOCKS

MUST BE INSERTED EXAMPLES OF APPLICATIONS WITH THE NEW FUNCTION BLOCKS

7. – 264IB used as LAS Backup Device

The 264IB Revision 1 is a Link Master device because it implements the LAS Back-up functionality. This feature is implemented on a dedicated unit not performing also the measurement tasks, providing enhanced security for the LAS function itself performed without using resources assigned to the measure.

The LAS Back-up function implemented in the 2600T-264IB supports the following characteristics:

- **1 Sub-schedule**
- **96 Sequences**
- **25 Elements for Sequence**

The Figure 14 shows how to enable/disable the LAS Backup function of the 264IB with the dedicated check mark in the configuration window of the ABB Engineering Station (Control Builder F for AC800F or Fieldbus Builder for AC800M).

Figure 14

The screenshot displays the configuration window for an ABB 264IB device. The 'Parameters: FF_DEVICE' dialog box is open, showing the following details:

- Tag name: FF_DEVICE_003
- Vendor: ABB
- Device type: 264IB
- Device ID: [empty]
- Bus address: 24

The 'LM settings' section is expanded, and the 'Backup Link Master' checkbox is checked, which is highlighted by a red circle. A red arrow points from the text above to this checkbox.

The background shows a hardware structure tree on the left and a table of blocks on the right:

Block ID	OD Index	Block
Resource Block	257	RB01
Transducer Block 1	340	TR80
Function Block 1	360	E-PID
Function Block 2	430	E-PID
Function Block 3	300	FB8031 ABB FIELD_INDICATOR
Function Block 4	500	AR - ABB
Function Block 5	540	CS - ABB
Function Block 6	570	IS - ABB

Referring to the Figure 15, whenever failure of the Controller occurs and the Primary LAS stops its execution, the Transmitter previously set as Back-up LAS take over the loop maintaining alive the fieldbus activity/communication executing the same macrocycle that was active before of the controller failure.

When more than 1 field device is configured as LAS Backup, the one with lower Node Address has high priority for assuming the control when the Primary LAS fails.

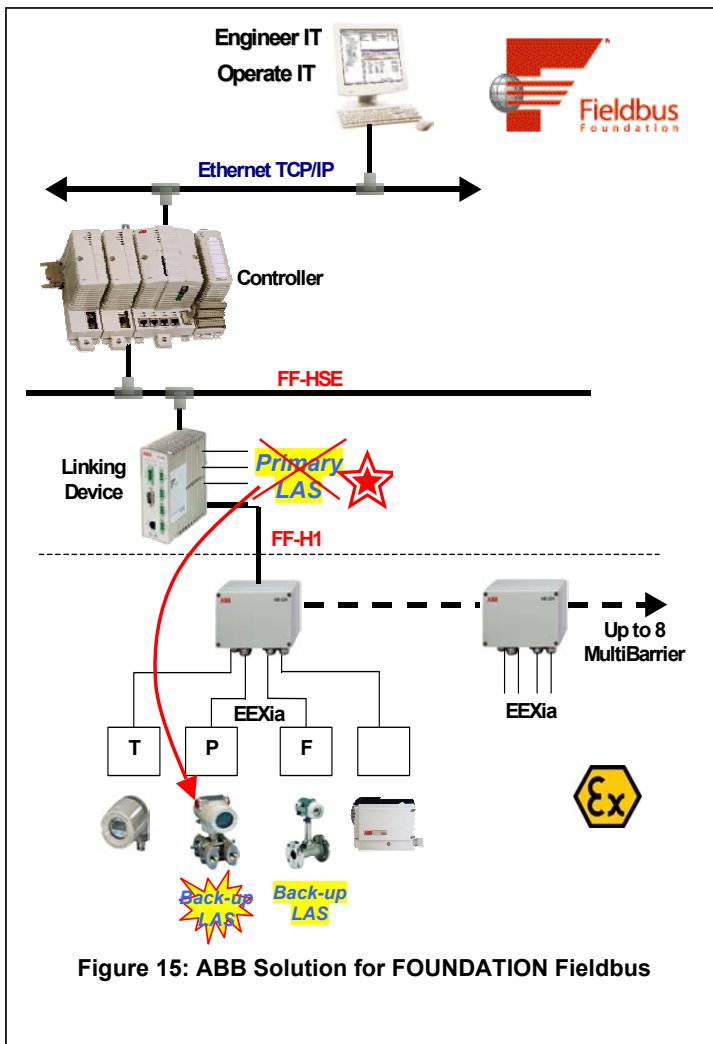

Further and detailed descriptions about the FOUNDATION Fieldbus concepts refers to the "Technical Overview" document **fd-043s** available on the Fieldbus Foundation website (www.fieldbus.org)

8. – Network Architecture

A typical ABB Solution for FOUNDATION Fieldbus is represented in the Figure 16.

The number of FF transmitters connected on one segment for EEx-ia applications can be increased when used in conjunction with the ABB Multibarrier MB204-EX.

It is possible to connect up to 8 multibarrier MB204-Ex on one EEx-ia segment and on each multibarrier is possible to connect up to 4 transmitters.

See an example of segment with Multibarrier in the Figure 16.

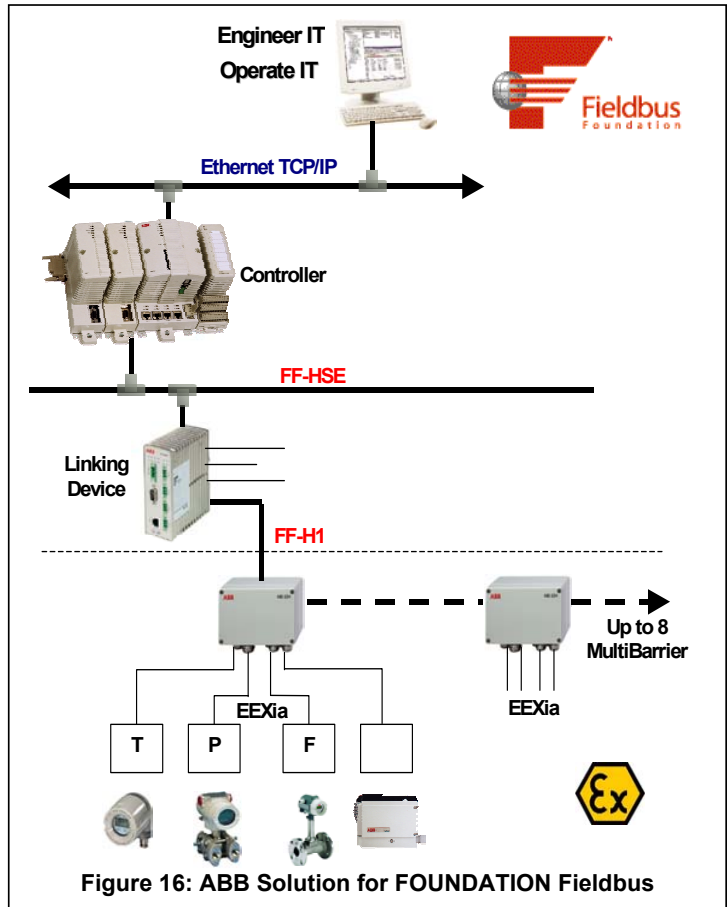

The network can be designed following 3 different topologies as shown in the Figure 17 below or can be applied as a mix of the three.

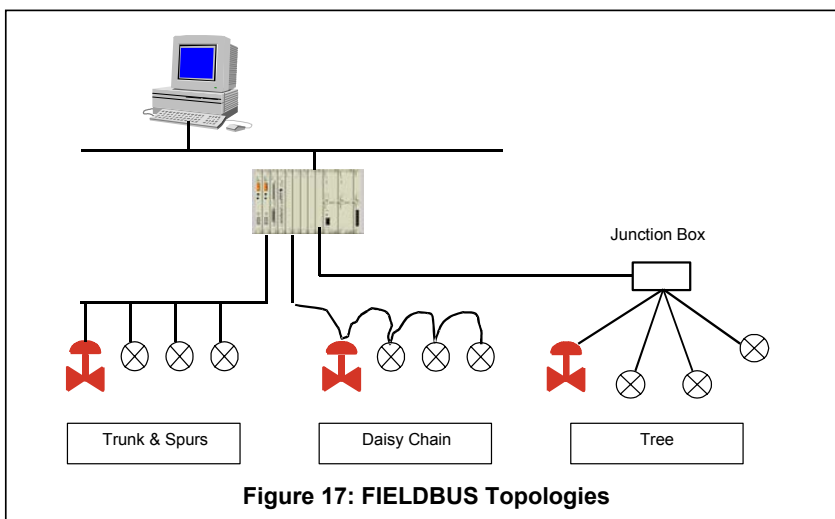

TABLE B

Parameters	Specifications	
Data Rate	31.25 Kbits/s	
Type	Voltage	
Topology	Bus/Tree	
Bus Power	Dc	
Intrinsically Safe	No	Yes
Max Number of Devices ⁽¹⁾	32	6
Max Cable length ⁽²⁾	1900 m	
Max Spurs length ⁽³⁾	120 m	

In the Table B are summarised some fieldbus characteristics.

- (1) The number of devices is strictly dependent by factors like the device power consumption, Type of cable used, additionally accessory devices such as repeaters and so on.
- (2) The maximum length includes the bus plus all the spurs length. The cable Type 'A' (#18 AWG 0.8 mm²) twisted pairs cable allows the maximum length of 1900 m.
- (3) The maximum Spur length is 120 m when only 1 device is connected. Any additional device reduces of 30 m the maximum Spur length.

The 2600T-264IB FF has the following power requirements:

- Current consumption: **10.5 mA ± 1 mA**
- Power Supply non Ex: **9 to 32 VDC**
- Power Supply Ex for **ENTITY** certification: **9 to 24 VDC**
- Power Supply Ex for **FISCO** certification: **9 to 17.5 VDC**

9. – FOUNDATION Fieldbus Overview

In the Figure 18, is represented how the Function Blocks inside the FF devices connected on the bus, can be linked together in order to achieve a simple control loop. After the loop has been designed, the LAS Master device, located in the Controller or, as back-up, in the slave device itself, starts the scheduling of the Function Block executions and of the publisher/subscriber communications in a deterministic way.

In the example of Figure 18, the Pressure Transmitter implementing the AI publish the pressure value, then the PID implemented in the valve, subscribe this value from the bus in order to be used as input for the PID. In the same way the exchange of values between the PID and the AO occurs but without communications on the bus, because the two Blocks are inside the same device.

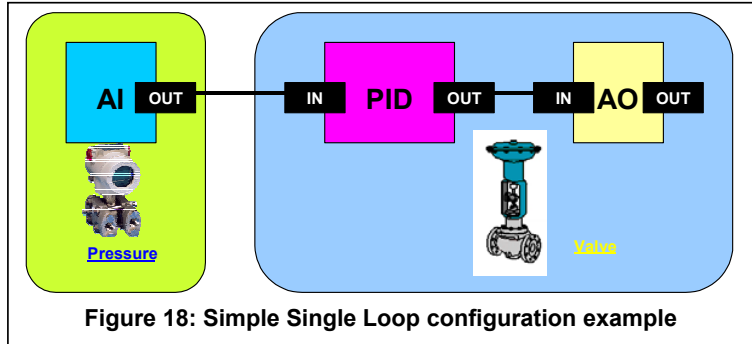

Figure 18: Simple Single Loop configuration example

In the Figure 19 is represented the macrocycle of the above loop. The LAS functionality inside the controller provides to handle the loop, and the macro-cycle is the temporary representation of how, function blocks and communications, are scheduled.

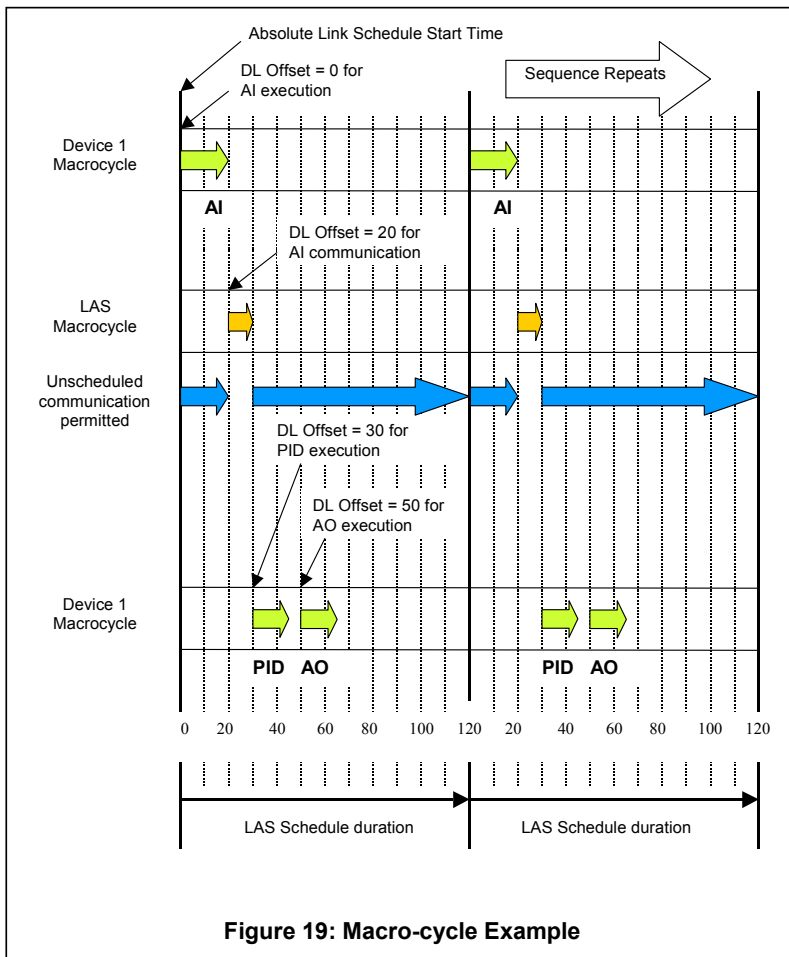

Figure 19: Macro-cycle Example

From the instant 0 to 20 the AI is executed, in the period from 20 to 30 the LAS provide to schedule the AI output. The Pressure Transmitter provides to publish the pressure value, the PID subscribes this value. Then the PID is executed from the instant 30 to 40 and at the end the PID output is scheduled and goes in input to the AO without communications because the two Function blocks reside inside the same device. The unscheduled communications are always active unless during the period between 20-30 when the pressure value is published on the bus.

10. – Device Addressing

When the 2600T-264IB is connected on a FF bus, the Master has to recognize it with a unique address in the world. For this reason the FF specifications define three different addressing levels that characterize the FF devices:

- The DEV_ID is the unique device identifier
- The PD_TAG is the physical name of the device
- The Node Address is the real node at which the device is connected on the bus. It is automatically set by the Master (Primary LAS) and its default value is **35**

The most important one with the higher priority is the DEV_ID. This is a string of 32 characters and must identify in a unique way each FF device in the world.

In order to fulfill this requirement the 2600T-264IB FF applies the following mechanism:

- The first part of the string is of 10 characters; the Manufacturer Code "000320" and Device Type code "0006".
- The second part of the string is of 12 characters and represent the device type identification; "_2600T_264IB".
- The third part of the string is of 10 characters and is filled with a progressive serial number. This number is written at factory configuration stage and it is assigned in a well-defined way just to be sure it is always different.

Finally the DEV_ID appears of 32 characters in this way '0003200006_2600T_264IBxxxxxxxx', where the entire 'x' represents the Serial number.

11. – Device Configuration

The 2600T-264IB offers a set of variables available through the FF communication. The Master for configuration and maintenance purposes can access the variables with Read and Write operations each addressed by an Index number. The FF Profile Standard defines the relative index of each variable, but the Start Index of each block is Manufacturer Specific.



In order to allow a full visibility and support of the variables mapped inside the 2600T-264IB it is necessary to import in the Master configuration system the DD files (.sym, and .ffo)

These files together with the Capability file (.cff) are available from the ABB SACE SpA or directly from the website <http://www.abb.com/instrumentation>.

These registered files have the following names:

- **0101.sym** as DD symbol file
- **0101.ffo** as DD object file
- **010101.cff** as Capability file.

The list of the variables available on the FF communication are reported in the following tables with the relevant block where:

IDX → Relative Index of the Variable

PC → Access Type for the variables.

Note: Some variables can be changed only if the relevant block is in Out of Service.

The RB, E-PID, CS are implemented in accordance with the Function Block Part 2 specification Document.

The IS, AR are implemented in accordance with the Function Block Part 3 specification Document.

For details about the meaning of each single variable refer at the FF Function Block Part 2 (Ref. 2), Part 3 (Ref. 3)

RESOURCE BLOCK

Idx	Name	Byte	PC	Description
0	BLOCK_OBJ	62	mix.	In the Block Object data structure, there are different items describing the block characteristics. Execution period, Number of parameters in the block, the DD Revision, Profile Revision, View Objects characteristics and so on
1	ST_REV	2	R	The revision level of the Static data associated with the Function Block. The revision level is incremented each time a static parameter value in the block is changed.
2	TAG_DESC	32	R/W	The user description of the intended application of the block
3	STRATEGY	2	R/W	The strategy field can be used to identify grouping of blocks. This data is not checked or processed by the block.
4	ALERT_KEY	1	R/W	The identification number of the plant unit. This information may be used in the host for sorting alarms, etc.
5	MODE_BLK	1	R/W	Target – The selected mode from the operator.
		1	R	Actual – The mode the block is currently in.
		1	R/W	Permitted – Allowed modes that the target may take on
		1	R/W	Normal – The common mode for the Actual.
6	BLOCK_ERR	2	R	This parameter reflects the error status associated with the hw or sw components associated with a block. It is a bit string, so that multiple errors may be shown.
7	RS_STATE	1	R	State machine of the function block application.
8	TEST_RW	112	R/W	Read/Write test parameter – used only for conformance testing.
9	DD_RESOURCE	32	R	String identifying the tag of the resource, which contains the Device Description for this resource.
10	MANUFAC_ID	4	R	Manufacturer Identification number – used by an interface device to locate the DD file for the resource. 000320 hex for ABB
11	DEV_TYPE	2	R	Manufacturer's model number associated with the resource – used by interface devices to locate the DD file for the resource.
12	DEV_REV	1	R	Manufacturer's revision number associated with the resource – used by interface devices to locate the DD file for the resource.
13	DD_REV	1	R	Revision of the DD associated with the resource – used by interface devices to locate the DD file for the resource.
14	GRANT_DENY	1	R/W	Grant
		1	R/W	Deny
15	HARD_TYPES	2	R	The type of Hardware available as channel numbers: 2. Scalar Output
16	RESTART	1	R/W	Allows a manual restart to be initiated. More restart are possible, they are: 1: Run – Normal state when running 2: Restart Resource 3: Restart with Default – Set the parameters to INITIAL VALUES. 4: Restart Processor – perform a warm start-up
17	FEATURES	2	R	Used to show supported resource block options. The 264IB supports the following: Bit 1 - Reports Supported Bit 2 - Fault State Supported Bit 3 - SW Write Lock Supported Bit 4 - HW Write Lock Supported Bit 5 - Output Read Back Supported
18	FEATURES_SEL	2	R/W	Used to select resource block options
19	CYCLE_TYPE	2	R	Identifies the block execution methods for this resource
20	CYCLE_SEL	2	R/W	Used to select the block execution methods for this resource. The 2600T-264IB supports the following: - Scheduled: Blocks are executed depending by the function block schedule. - Block execution: A block may be executed by linking to another block completion.
21	MIN_CYCLE_T	4	R	Time duration of the shorted cycle interval of which the resource is capable.
22	MEMORY_SIZE	2	R	Available configuration memory in the empty resource. To be checked before attempting a download
23	NV_CYCLE_TIME	4	R	Minimum time interval for writing copies of NV parameters to non-volatile memory. Zero means it will be never automatically copied.
24	FREE_SPACE	4	R	Percent of memory available for further configuration. Zero in a pre-configured device
25	FREE_TIME	4	R	Percent of the block processing time that is free to process additional blocks.
26	SHED_RCAS	4	R/W	Time duration at which to give up on computer writes to function block Rcas locations. Shed from Rcas shall never happen when Shed_Rcas = 0
27	SHED_ROUT	4	R/W	Time duration at which to give up on computer writes to function block Rout locations. Shed from Rout shall never happen when Shed_Rout = 0
28	FAULT_STATE	1	R	Fault State
29	SET_FSTATE	1	R/W	Set Fault State
30	CLR_FSTATE	1	R/W	Clear Fault State
31	MAX_NOTIFY	1	R	Maximum number of unconfirmed alert notify messages possible
32	LIM_NOTIFY	1	R/W	Maximum number of unconfirmed alert notify messages allowed
33	CONFIRM_TIME	4	R/W	The minimum time between retries of alert report. Retries shall not happen when Confirm_Time = 0
34	WRITE_LOCK	1	R/W	If set, no writes from anywhere are allowed except to clear Write_Lock. Block inputs will continue to be updated.

35	UPDATE_EVT			This alert is generated by any change to the static data.
		1	R/W	Unacknowledged:
		1	R	Update State:
		8	R	Time Stamp: The date and time of when the alert was generated
		2	R	Static Revision: The number of the last increment generating the alert
		2	R	Relative Index: The index of the changed variable generating the alert
36	BLOCK_ALM	The block alarm is used for all configuration, hardware, connection failures or system problems in the block. The cause of the alert is entered in the sub-code field. The first alert to become active will set the Active Status in the status parameter. As soon as the Unreported status is cleared by the alert reporting task, another block alert may be reported without clearing the Active Status, if the sub-code has changed		
		1	R/W	Unacknowledged
		1	R	Alarm State
		8	R	Time Stamp: The date and time of when the alert was generated
		2	R	Sub-code: Cause of the alert
		1	R	Value: The value generating the alert
37	ALARM_SUM	The alert status associated to the function block		
		2	R	Current
		2	R	Unacknowledged
		2	R	Unreported
		2	R/W	Disabled
38	ACK_OPTION	2	R/W	Selection of whether alarms associated the function block will be automatically acknowledged.
39	WRITE_PRI	1	R/W	Priority of the alarm generated by clearing the write_lock
40	WRITE_ALM	This alert is generated if the write_lock parameter is cleared		
		1	R/W	Unacknowledged
		1	R	Alarm State
		8	R	Time Stamp: The date and time of when the alert was generated
		2	R	Sub-code
		1	R	Value
41	ITK_VER	2	R	Major revision number of the Interoperability test case used in certifying this device as interoperable
42	TX_SERIAL_NUM	16	R	Serial Number of the Transmitter (FAN – Finally Assembly Number)

E-PID FUNCTION BLOCK

Idx	Name	Byte	PC	Description
0	BLOCK_OBJ	62	mix.	In the Block Object data structure, there are different items describing the block characteristics. Execution period, Number of parameters in the block, the DD Revision, Profile Revision, View Objects characteristics and so on
1	ST_REV	2	R	The revision level of the Static data associated with the Function Block. The revision level is incremented each time a static parameter value in the block is changed.
2	TAG_DESC	32	R/W	The user description of the intended application of the block
3	STRATEGY	2	R/W	The strategy field can be used to identify grouping of blocks. This data is not checked or processed by the block.
4	ALERT_KEY	1	R/W	The identification number of the plant unit. This information may be used in the host for sorting alarms, etc.
5	MODE_BLK	1	R/W	Target – The selected mode from the operator.
		1	R	Actual – The mode the block is currently in.
		1	R/W	Permitted – Allowed modes that the target may take on
		1	R/W	Normal – The common mode for the Actual.
6	BLOCK_ERR	2	R	This parameter reflects the error status associated with the hw or sw components associated with a block. It is a bit string, so that multiple errors may be shown.
7	PV	4	R	The process variable used in block execution, expressed in PV_SCALE Unit Code
		1	R	The process variable status
8	SP	4	R/W	The analog Set Point value of this block, expressed in PV_SCALE Unit Code
		1	R/W	The analog Set Point status of this block
9	OUT	4	R	The block output value calculated as a result of the block execution, in OUT_SCALE unit code. Only when the function block is in Manual MODE this variable can be written
		1	R	The block output status
10	PV_SCALE	4	R/W	High Range
		4	R/W	Low Range
		2	R/W	Unit Index
		1	R/W	Decimal point
11	OUT_SCALE	4	R/W	High Range
		4	R/W	Low Range
		2	R/W	Unit Index
		1	R/W	Decimal point
12	GRANT_DENY	1	R/W	Grant
		1	R/W	Deny
13	CONTROL_OPTS	2	R/W	Options the user may select to alter the calculation done in a control loop. Supported are: bit 0 – Bypass enabled bit 1 – SP-PV track in MAN bit 2 – SP-PV track in Rout bit 3 – SP-PV track in LO or IMAN bit 4 – SP track retained target bit 5 – Direct acting bit 7 – Track enable bit 8 – Track in Manual bit 9 – Use PV for BKCAL_OUT bit 12 – Obey limits if CAS or RCAS bit 13 – No out limits in Manual
14	STATUS_OPTS	2	R/W	Options the user can select for block processing of status. They are: bit 0 – Initiate Fault State if BAD IN bit 1 – Initiate Fault State if BAD CAS_IN bit 2 – Use Uncertain as Good bit 5 – Target to Manual if BAD IN bit 9 – Target AUTO if BAD CAS_IN
15	IN	4	R/W	The Primary Input Value for the block coming from another block, in PV_SCALE Unit
		1	R/W	The Primary Input Status
16	PV_FTIME	4	R/W	Time constant of a single exponential filter for the PV, expressed in seconds. This is the time necessary for reach the 63% of the variation of IN value.
17	BYPASS	1	R/W	The normal control algorithm may be bypassed trough this parameter. When bypass is set, the set point value (in percent) will be directly transferred to the output.
18	CAS_IN	4	R/W	Remote set point value from another block. Expressed in PV_SCALE Unit Code
		1	R/W	Remote set point status from another block
19	SP_RATE_DN	4	R/W	Ramp rate for downward SP changes. When the ramp rate is set to zero the SP is used immediately. Expressed in PV_SCALE Unit Code per seconds
20	SP_RATE_UP	4	R/W	Ramp rate for upward SP changes. When the ramp rate is set to zero the SP is used immediately. Expressed in PV_SCALE Unit Code per seconds
21	SP_HI_LIM	4	R/W	The Highest Set Point value allowed. Expressed in PV_SCALE Unit Code
22	SP_LO_LIM	4	R/W	The Lowest Set Point value allowed. Expressed in PV_SCALE Unit Code
23	GAIN	4	R/W	The proportional gain value.
24	RESET	4	R/W	The integral time constant, in seconds per repeat.
25	BAL_TIME	4	R/W	The specified time for the internal working value of bias to return to operator set bias. Also used to specify the time constant at which the integral term will move to obtain balance when the output is limited and the mode is AUTO, CAS, or RCAS. Expressed in seconds
26	RATE	4	R/W	The derivative action time constant expressed in seconds
27	BKCAL_IN	4	R/W	The analog input value from another block's BKCAL_OUT output that is used to prevent reset windup and to initialise the control loop. Expressed in OUT_SCALE Unit Code
		1	R/W	Back Calculation Input Status
28	OUT_HI_LIM	4	R/W	The max. Output value allowed. Expressed in OUT_SCALE Unit Code

29	OUT_LO_LIM	4	R/W	The min. Output value allowed. Expressed in OUT_SCALE Unit Code
30	BKCAL_HYS	4	R	The amount that the output must change away from its output limit before the limit status is turned off. Expressed as percent of the OUT_SCALE span
31	BKCAL_OUT	4	R	The value required by an upper block's BKCAL_IN so that the upper block may prevent reset windup and provides bumpless transfer to closed control loop. Expressed in PV_SCALE Unit Code
		1	R	Back Calculation Status
32	RCAS_IN	4	R/W	Target set-point value provided by a supervisory host. Used when mode is RCAS. Expressed in PV_SCALE Unit Code.
		1	R/W	RCAS_IN Status
33	ROUT_IN	4	R/W	Target output value provided by a supervisory host. Used when the mode is ROUT. Expressed in OUT_SCALE Unit Code
		1	R/W	ROUT_IN Status
34	SHED_OPT	1	R/W	Define actions to be taken on remote control device timeout
35	RCAS_OUT	4	R	Block set-point Value after ramping – provided by a supervisory host for back calculations and to allow action to be taken under limiting conditions or mode change. Used when mode is RCAS. Expressed in PV_SCALE Unit Code
		1	R	RCAS_OUT Status
36	ROUT_OUT	4	R	Block output Value provided to a supervisory host for a back calculation to allow action to be taken under limiting conditions or mode change. Used when mode is ROUT. Expressed in OUT_SCALE Unit Code
		1	R	ROUT_OUT Status
37	TRK_SCALE	4	R/W	High Range
		4	R/W	Low Range
		2	R/W	Unit Index
		1	R/W	Decimal point
				All the values are associated with the external tracking value (TRK_VAL)
38	TRK_IN_D	2	R/W	Discrete input used to initiate external tracking of the block output to the value specified by the TRK_VAL
39	TRK_VAL	4	R/W	This input is used as tack value when external tracking is enabled by TRK_IN_D, expressed in TRK_SCALE Unit Code.
		1	R/W	Tracking Status
40	FF_VAL	4	R/W	The Feed-Forward Control Value. Expressed in FF_SCALE Unit Code
		1	R/W	The Feed-Forward Control Status
41	FF_SCALE	4	R/W	High Range
		4	R/W	Low Range
		2	R/W	Unit Index
		1	R/W	Decimal point
				All the values are associated with the feed forward value (FF_VAL)
42	FF_GAIN	4	R/W	The gain that the feed forward input is multiplied by before it is added to the calculated control loop.
43	UPDATE_EVT	This alert is generated by any change to the static data		
		1	R/W	Unacknowledged
		1	R	Update State
		8	R	Time Stamp: The date and time of when the alert was generated
		2	R	Static Revision
		2	R	Relative Index
44	BLOCK_ALM	The block alarm is used for all configuration, hardware, connection failures or system problems in the block. The cause of the alert is entered in the sub-code field. The first alert to become active will set the Active Status in the status parameter. As soon as the Unreported status is cleared by the alert reporting task, another block alert may be reported without clearing the Active Status, if the subcode has changed		
		1	R/W	Unacknowledged
		1	R	Alarm State
		8	R	Time Stamp: The date and time of when the alert was generated
		2	R	Sub-code
		1	R	Value
45	ALARM_SUM	The summary alarm is used for all process alarm in the block. The cause of the alert is entered in the sub-code field. The first alert to become active will set the Active Status in the status parameter. As soon as the Unreported status is cleared by the alert reporting task, another block alert may be reported without clearing the Active Status, if the sub-code has changed		
		2	R	Current
		2	R	Unacknowledged
		2	R	Unreported
		2	R/W	Disabled
46	ACK_OPTION	2	R/W	Used to set auto acknowledgment of the alarms
47	ALARM_HYS	4	R/W	Amount the PV must return within the alarm limit before the alarm condition clears. Alarm Hysteresis is expressed as percent of the OUT_SCALE span.
48	HI_HI_PRI	1	R/W	Priority of HI_HI_ALM
49	HI_HI_LIM	4	R/W	The setting of the High High Limit producing the High High Alarm in OUT_SCALE Unit
50	HI_PRI	1	R/W	Priority of HI_ALM
51	HI_LIM	4	R/W	The setting of the High Limit producing the High Alarm in OUT_SCALE Unit Code
52	LO_PRI	1	R/W	Priority of LO_ALM
53	LO_LIM	4	R/W	The setting of the Low Limit producing the Low Alarm in OUT_SCALE Unit Code
54	LO_LO_PRI	1	R/W	Priority of LO_LO_ALM
55	LO_LO_LIM	4	R/W	The setting of the Low Low Limit producing the Low Low Alarm in OUT_SCALE Unit Code
56	DV_HI_PRI	1	R/W	The Priority of DV_HI_ALM

57	DV_HI_LIM	4	R/W	Setting of the Deviation High Limit producing the Deviation High Alarm, in OUT_SCALE UnitCode
58	DV_LO_PRI	1	R/W	The Priority of DV_LO_ALM
59	DV_LO_LIM	4	R/W	Setting of the Deviation Low Limit producing the Deviation Low Alarm, in OUT_SCALE Unit Code
60	HI_HI_ALM	High High Alarm data		
		1	R/W	Unacknowledged
		1	R	Alarm State
		8	R	Time Stamp: The date and time of when the alert was generated
		2	R	Sub-code
61	HI_ALM	High Alarm data		
		1	R/W	Unacknowledged
		1	R	Alarm State
		8	R	Time Stamp: The date and time of when the alert was generated
		2	R	Sub-code
62	LO_ALM	Low Alarm data		
		1	R/W	Unacknowledged
		1	R	Alarm State
		8	R	Time Stamp: The date and time of when the alert was generated
		2	R	Sub-code
63	LO_LO_ALM	Low Low Alarm data		
		1	R/W	Unacknowledged
		1	R	Alarm State
		8	R	Time Stamp: The date and time of when the alert was generated
		2	R	Sub-code
64	DV_HI_ALM	Deviation High Alarm data		
		1	R/W	Unacknowledged
		1	R	Alarm State
		8	R	Time Stamp: The date and time of when the alert was generated
		2	R	Sub-code
65	DV_LO_ALM	Deviation Low Alarm data		
		1	R/W	Unacknowledged
		1	R	Alarm State
		8	R	Time Stamp: The date and time of when the alert was generated
		2	R	Sub-code
66	T1_RATE	4	R/W	Derivative 1 st order filter
67	BETA	4	R/W	Set-point weight proportional part
68	GAMMA	4	R/W	Set-point weight derivative part

ARITHMETIC FUNCTION BLOCK

Idx	Name	Byte	PC	Description
0	BLOCK_OBJ	62	mix.	In the Block Object data structure, there are different items describing the block characteristics. Execution period, Number of parameters in the block, the DD Revision, Profile Revision, View Objects characteristics and so on
1	ST_REV	2	R	The revision level of the Static data associated with the Function Block. The revision level is incremented each time a static parameter value in the block is changed.
2	TAG_DESC	32	R/W	The user description of the intended application of the block
3	STRATEGY	2	R/W	The strategy field can be used to identify grouping of blocks. This data is not checked or processed by the block.
4	ALERT_KEY	1	R/W	The identification number of the plant unit. This information may be used in the host for sorting alarms, etc.
5	MODE_BLK	1	R/W	Target – The selected mode from the operator.
		1	R	Actual – The mode the block is currently in.
		1	R/W	Permitted – Allowed modes that the target may take on
		1	R/W	Normal – The common mode for the Actual.
6	BLOCK_ERR	2	R	This parameter reflects the error status associated with the hw or sw components associated with a block. It is a bit string, so that multiple errors may be shown.
7	PV	4	R	The process variable used in block execution, expressed in PV_SCALE Unit Code
		1	R	The process variable status
8	OUT	4	R	The block output value calculated as a result of the block execution, in OUT_SCALE unit code. Only when the function block is in Manual MODE this variable can be written
		1	R	The block output status
9	PRE_OUT	4	R	Display what would be the Out Value if the mode was AUTO or lower
		1	R	Display what would be the Out Status if the mode was AUTO or lower

10	PV_SCALE	4	R/W	High Range	All the values are associated with the PV
		4	R/W	Low Range	
		2	R/W	Unit Index	
		1	R/W	Decimal point	
11	OUT_RANGE	4	R/W	High Range	
		4	R/W	Low Range	
		2	R/W	Unit Index	
		1	R/W	Decimal point	
12	GRANT_DENY	1	R/W	Grant	
		1	R/W	Deny	
13	INPUT_OPTS	2	R/W	Options the user may select to alter the calculation done in a control loop. Supported are: bit 0 - IN Use uncertain bit 1 - IN LO Use uncertain bit 2 - IN_1 Use uncertain bit 3 - IN_1 Use bad bit 4 - IN_2 Use uncertain bit 5 - IN_2 Use bad bit 6 - IN_3 Use uncertain bit 7 - IN_3 Use bad	
14	IN	4	R/W	The Primary Input Value for the block coming from another block, in PV_SCALE Unit	
		1	R/W	The Primary Input Status	
15	IN_LO	4	R/W	The process variable used in block execution, expressed in PV_SCALE Unit Code	
		1	R/W	The process variable status	
16	IN_1	4	R/W	The process variable used in block execution, expressed in PV_SCALE Unit Code	
		1	R/W	The process variable status	
17	IN_2	4	R/W	The process variable used in block execution, expressed in PV_SCALE Unit Code	
		1	R/W	The process variable status	
18	IN_3	4	R/W	The process variable used in block execution, expressed in PV_SCALE Unit Code	
		1	R/W	The process variable status	
19	RANGE_HI	4	R/W	Constant Value above which the range extension has switched to the high range transmitter.	
20	RANGE_LO	4	R/W	Constant Value below which the range extension has switched to the low range transmitter.	
21	BIAS_IN_1	4	R/W	The constant to be added to IN_1	
22	GAIN_IN_1	4	R/W	The constant to be multiplied times (IN_1 + Bias)	
23	BIAS_IN_2	4	R/W	The constant to be added to IN_2	
24	GAIN_IN_2	4	R/W	The constant to be multiplied times (IN_2 + Bias)	
25	BIAS_IN_3	4	R/W	The constant to be added to IN_3	
26	GAIN_IN_3	4	R/W	The constant to be multiplied times (IN_3 + Bias)	
27	COMP_HI_LIM	4	R/W	The Highest Set Point value allowed. Expressed in PV_SCALE Unit Code	
28	COMP_LO_LIM	4	R/W	The Lowest Set Point value allowed. Expressed in PV_SCALE Unit Code	
29	ARITH_TYPE	1	R/W	Type of Arithmetic function: 1. Flow Compensation, Linear 2. Flow Compensation, Square Root 3. Flow Compensation, Approximate 4. BTU Flow 5. Traditional Multiple Divide 6. Average 7. Traditional Summer 8. Fourth Order Polynomial 9. Simple HTG compensated Level	
30	BAL_TIME	4	R/W	The specified time for the internal working value of bias to return to operator set bias. Also used to specify the time constant at which the integral term will move to obtain balance when the output is limited and the mode is AUTO, CAS, or RCAS. Expressed in seconds	
31	BIAS	4	R/W	The bias Value used in computing the function block output expressed in engineering unit	
32	GAIN	4	R/W	Dimensionless Value used by the block algorithm in calculating the block output	
33	OUT_HI_LIM	4	R/W	The max. Output value allowed. Expressed in OUT_SCALE Unit Code	
34	OUT_LO_LIM	4	R/W	The min. Output value allowed. Expressed in OUT_SCALE Unit Code	
35	UPDATE_EVT	This alert is generated by any change to the static data			
		1	R/W	Unacknowledged	
		1	R	Update State	
		8	R	Time Stamp: The date and time of when the alert was generated	
		2	R	Static Revision	
		2	R	Relative Index	
36	BLOCK_ALM	The block alarm is used for all configuration, hardware, connection failures or system problems in the block. The cause of the alert is entered in the sub-code field. The first alert to become active will set the Active Status in the status parameter. As soon as the Unreported status is cleared by the alert reporting task, another block alert may be reported without clearing the Active Status, if the subcode has changed			
		1	R/W	Unacknowledged	
		1	R	Alarm State	
		8	R	Time Stamp: The date and time of when the alert was generated	
		2	R	Sub-code	
		1	R	Value	

CONTROL SELECTOR FUNCTION BLOCK

Idx	Name	Byte	PC	Description
0	BLOCK_OBJ	62	mix.	In the Block Object data structure, there are different items describing the block characteristics. Execution period, Number of parameters in the block, the DD Revision, Profile Revision, View Objects characteristics and so on
1	ST_REV	2	R	The revision level of the Static data associated with the Function Block. The revision level is incremented each time a static parameter value in the block is changed.
2	TAG_DESC	32	R/W	The strategy field can be used to identify grouping of blocks. This data is not checked or processed by the block.
3	STRATEGY	2	R/W	The identification number of the plant unit. This information may be used in the host for sorting alarms, etc.
4	ALERT_KEY	1	R/W	The identification number of the plant unit. This info may be used in the host for sorting alarms, etc.
5	MODE_BLK	1	R/W	Target – The selected mode from the operator.
		1	R	Actual – The mode the block is currently in.
		1	R/W	Permitted – Allowed modes that the target may take on
		1	R/W	Normal – The common mode for the Actual.
6	BLOCK_ERR	2	R	This parameter reflects the error status associated with the hw or sw components associated with a block. It is a bit string, so that multiple errors may be shown.
7	OUT	4	R	The block output value calculated as a result of the block execution, in OUT_SCALE unit code. Only when the function block is in Manual MODE this variable can be written
		1	R	The block output status
8	OUT_SCALE	4	R/W	High Range
		4	R/W	Low Range
		2	R/W	Unit Index
		1	R/W	Decimal point
9	GRANT_DENY	1	R/W	Grant
		1	R/W	Deny
10	STATUS_OPTS	2	R/W	Options the user may select to alter the calculation done in a control loop. Supported are: bit 0 - IFS if BAD IN bit 2 - Use Uncertain as GOOD
11	SEL_1	4	R/W	First input Value to the selector
		1	R/W	First input Status to the selector
12	SEL_2	4	R/W	Second input Value to the selector
		1	R/W	Second input Status to the selector
13	SEL_3	4	R/W	Third input Value to the selector
		1	R/W	Third input Status to the selector
14	SEL_TYPE	1	R/W	Control Selection Type: 1- High 2- Low 3- Middle
15	BKCAL_IN	4	R/W	The analog input value from another block's BKCAL_OUT output that is used to prevent reset windup and to initialize the control loop. Expressed in OUT_SCALE Unit Code
		1	R/W	Back Calculation Input Status
16	OUT_HI_LIM	4	R/W	The max. Output value allowed. Expressed in OUT_SCALE Unit Code
17	OUT_LO_LIM	4	R/W	The min. Output value allowed. Expressed in OUT_SCALE Unit Code
18	BKCAL_SEL_1	4	R/W	Control selector Value associated with SEL_1 input which is provided to BKCAL_IN of the block connected to SEL_1 in order to prevent reset windup
		1	R/W	Control Selector Status associated with SEL_1
19	BKCAL_SEL_2	4	R/W	Control selector Value associated with SEL_2 input which is provided to BKCAL_IN of the block connected to SEL_2 in order to prevent reset windup
		1	R/W	Control Selector Status associated with SEL_2
20	BKCAL_SEL_3	4	R/W	Control selector Value associated with SEL_3 input which is provided to BKCAL_IN of the block connected to SEL_3 in order to prevent reset windup
		1	R/W	Control Selector Status associated with SEL_3
21	UPDATE_EVT	This alert is generated by any change to the static data		
		1	R/W	Unacknowledged
		1	R	Update State
		8	R	Time Stamp: The date and time of when the alert was generated
		2	R	Static Revision
		2	R	Relative Index
22	BLOCK_ALM	The block alarm is used for all configuration, hardware, connection failures or system problems in the block. The cause of the alert is entered in the sub-code field. The first alert to become active will set the Active Status in the status parameter. As soon as the Unreported status is cleared by the alert reporting task, another block alert may be reported without clearing the Active Status, if the subcode has changed		
		1	R/W	Unacknowledged
		1	R	Alarm State
		8	R	Time Stamp: The date and time of when the alert was generated
		2	R	Sub-code
		1	R	Value

MUX FUNCTION BLOCK

Idx	Name	Byte	PC	Description
0	BLOCK_OBJ	62	mix.	In the Block Object data structure, there are different items describing the block characteristics. Execution period, Number of parameters in the block, the DD Revision, Profile Revision, View Objects characteristics and so on
1	ST_REV	2	R	The revision level of the Static data associated with the Function Block. The revision level is incremented each time a static parameter value in the block is changed.
2	TAG_DESC	32	R/W	The user description of the intended application of the block
3	STRATEGY	2	R/W	The strategy field can be used to identify grouping of blocks. This data is not checked or processed by the block.
4	ALERT_KEY	1	R/W	The identification number of the plant unit. This information may be used in the host for sorting alarms, etc.
5	MODE_BLK	1	R/W	Target – The selected mode from the operator.
		1	R	Actual – The mode the block is currently in.
		1	R/W	Permitted – Allowed modes that the target may take on
		1	R/W	Normal – The common mode for the Actual.
6	BLOCK_ERR	2	R	This parameter reflects the error status associated with the hw or sw components associated with a block. It is a bit string, so that multiple errors may be shown.
7	OUT	4	R	The block output value calculated as a result of the block execution, in OUT_SCALE unit code. Only when the function block is in Manual MODE this variable can be written
		1	R	The block output status
8	GRANT_DENY	1	R/W	Grant
		1	R/W	Deny
9	IN_SELECT	1	R/W	This parameter reflects the value of the selected inputs in a range between 1-9
10	IN_1	4	R/W	Input 1 Value received in input via a Publisher/Subscriber telegram
		1	R/W	Input 1 Status received in input via a Publisher/Subscriber telegram
11	IN_2	4	R/W	Input 2 Value received in input via a Publisher/Subscriber telegram
		1	R/W	Input 2 Status received in input via a Publisher/Subscriber telegram
12	IN_3	4	R/W	Input 3 Value received in input via a Publisher/Subscriber telegram
		1	R/W	Input 3 Status received in input via a Publisher/Subscriber telegram
13	IN_4	4	R/W	Input 4 Value received in input via a Publisher/Subscriber telegram
		1	R/W	Input 4 Status received in input via a Publisher/Subscriber telegram
14	IN_5	4	R/W	Input 5 Value received in input via a Publisher/Subscriber telegram
		1	R/W	Input 5 Status received in input via a Publisher/Subscriber telegram
15	IN_6	4	R/W	Input 6 Value received in input via a Publisher/Subscriber telegram
		1	R/W	Input 6 Status received in input via a Publisher/Subscriber telegram
16	IN_7	4	R/W	Input 7 Value received in input via a Publisher/Subscriber telegram
		1	R/W	Input 7 Status received in input via a Publisher/Subscriber telegram
17	IN_8	4	R/W	Input 8 Value received in input via a Publisher/Subscriber telegram
		1	R/W	Input 8 Status received in input via a Publisher/Subscriber telegram
18	HOST_IN	4	R/W	Value coming from the Host with a direct writing via Client/Server telegrams
		1	R/W	Status coming from the Host with a direct writing via Client/Server telegrams
19	IN_1_UNIT	2	R/W	Input 1 Unit Code
20	IN_2_UNIT	2	R/W	Input 2 Unit Code
21	IN_3_UNIT	2	R/W	Input 3 Unit Code
22	IN_4_UNIT	2	R/W	Input 4 Unit Code
23	IN_5_UNIT	2	R/W	Input 5 Unit Code
24	IN_6_UNIT	2	R/W	Input 6 Unit Code
25	IN_7_UNIT	2	R/W	Input 7 Unit Code
26	IN_8_UNIT	2	R/W	Input 8 Unit Code
27	HOST_IN_UNIT	2	R/W	Host Input Unit Code
28	IN_1_TAG	16	R/W	Input 1 TAG
29	IN_2_TAG	16	R/W	Input 2 TAG
30	IN_3_TAG	16	R/W	Input 3 TAG
31	IN_4_TAG	16	R/W	Input 4 TAG
32	IN_5_TAG	16	R/W	Input 5 TAG
33	IN_6_TAG	16	R/W	Input 6 TAG
34	IN_7_TAG	16	R/W	Input 7 TAG
35	IN_8_TAG	16	R/W	Input 8 TAG
36	HOST_IN_TAG	16	R/W	Host Input TAG
37	SEQUENCE	1	R/W	This variable enable or disable the automatic scrolling of the active linked inputs
				1- No Automatic Scrolling 2- Automatic Scrolling (every 5 seconds only the linked inputs)
38	UPDATE_EVT			This alert is generated by any change to the static data
		1	R/W	Unacknowledged
		1	R	Update State
		8	R	Time Stamp: The date and time of when the alert was generated
		2	R	Static Revision
		2	R	Relative Index

12. - Operating Modes

As defined by the FOUNDATION™ fieldbus specifications, the Resource and Function Blocks have to satisfy defined operating modes each represented by a proper bit in the MODE_BLK_PERMITTED data structure. (See section 11)

RB Modes	AR Modes	IS Modes	CS Modes	EPID Modes	MUX Modes	TB Modes
- IMAN	- MAN	- MAN	- MAN	- Manual (MAN)	- MAN	- AUTO
- AUTO	- AUTO	- AUTO	- AUTO	- Automatic (AUTO)	- AUTO	- O/S
- O/S	- O/S	- O/S	- IMAN	- Out of Service (O/S)	- O/S	
			- O/S	- IMAN (Initialisation Manual)		
				- CAS (Cascade)		
				- RCAS (Remote Cascade)		
				- ROUT (Remote Output)		
				- LO (Local Override)		

When the RB is Out of Service, all the other blocks are forced in Out of Service too.

13. - Diagnostic

The FOUNDATION™ Fieldbus defines different ways to report diagnostics information. Standard and Manufacturer specific variables include and represent diagnostic Flags/Codes updated dynamically every DSP loop.

First of all it is necessary to distinguish between the flags available only when accessed from the user with a read operation, and the other which in addition, enable the Alert Notification mechanism if allowed by the ALARM_SUMMARY disabled variable. The notification provides to automatically inform the Master about the occurred event with the information defined in the Alert_Discrete data structure. These events could be then acknowledged or not depending by the operator at the Master side. These events are notified only when the error appear, there are not notifications when the error conditions disappear.

Furthermore the Alert Notification mechanism is used to notify to the Master not only error conditions, but also some process conditions.

For example whenever the OUT value of the EPID goes outside the Advisory and/or Critical limits, the notification mechanism get starts only if enabled in the ALARM_SUMMARY disabled variable. The notification provides to inform the Master about the OUT value which enabled the event, the time and date of the occurred event (Time_Stamp), and other information defined in the Alert_Float data structure. The alarm could be then acknowledged or not depending by the operator at the Master side. Respect the errors handling, the same mechanism is enabled also when the OUT value came back inside the Advisory and/or Critical limits.

The FOUNDATION™ Fieldbus defines also others events which have to be automatically notified to the Master. Each changing of the HW and/or SW security locking condition is notified trough an Alert_Discrete data structure, and every changing of the variable's value, which consequently requires the increment the Static Revision value, is notified with the information of the Alert_Update data structure.

Only for the notifications of Alert_Update type is not contemplated the acknowledgement form the Master.

Each Block implemented in the 264IB includes the BLOCK_ERR bitstring variable, and each bit represents an error condition. Some of these bits can also be source of the Alert Notification mechanism. See the sections 13.2, 13.3.

Whenever an error or alarm condition enables an Alert Notification mechanism, it can assume different state machine conditions like acknowledged, unacknowledged, reported, unreported and so on. The complete status of each supported alarm is summarised by the ALARM_SUMMARY variable. See the section 13.1.

Another information to be considered for possible diagnostic usage is the Status byte that is produced every loop together with some dynamic variables like the OUT value of the Function Blocks. It represents the Quality of the associated variable. See the section 13.5.

13.1 – Alarm Summary

The ALARM_SUMMARY data structure reflects the general status of the alarms handled in the 2600T-2641B. The bits listed below represent the alarms supported in the 2641B, and each of them is available with 4 information:

1. Current Alarms
2. Unacknowledged
3. Unreported
4. Disabled

Whenever the alarm is enabled in the Disabled field, and the alarm condition occurs, it is notified at the Master through the Alert Notification state machine and the relevant bit is set in the Current Alarms field. The Unacknowledged field reflects if the alarm has been recognised at the Master side. The Unreported field reflects if the alarm was linked to a system at which each alarm event has to be reported.

Octet	Bit	Mnemonic	Description
1	0	Discrete Alarm	Supported only by the Resource Block. When the HW (Switch 1) and/or SW write locking change its status.
	1	HI_HI_Alarm	Supported by EPID. Notified when the OUT value goes over the HI_HI_LIM value, and also when the OUT value came back below the HI_HI_LIM value.
	2	HI_Alarm	Supported by EPID. Notified when the OUT value goes over the HI_LIM value, and also when the OUT value came back below the HI_LIM value.
	3	LO_LO_Alarm	Supported by EPID. Notified when the OUT value goes below the LO_LO_LIM value, and also when the OUT value came back over the LO_LO_LIM value.
	4	LO_Alarm	Supported by EPID. Notified when the OUT value goes below the LO_LIM value, and also when the OUT value came back over the LO_LIM value.
	5	DEV_HI_Alarm	Supported only by EPID
	6	DEV_LO_Alarm	Supported only by EPID
2	7	Block Alarm	Supported by RB, IS, CS, PID, MUX, AR, TB. Notify every Block Error occurrence of the relating block. See 13.3 – Block Error.
	0-7	Reserved	

Limit alarm bits will be set to 1 or 0 if the alarm reason occurs (1) or is gone (0) in the Current Alarms field.

13.2 – Alarm Priority

For each alarm there is the possibility to select the correspondent priority level between 0 - 15. The Table F below defines what the different priority means.

TABLE F:

Alarm Priority	Description
0	Alarm is Suppressed
1	Recognised by the system but not reported
2	Report to the operator, but doesn't require his attention
3 – 7	Advisory alarm of increasing priority
8 – 15	Critical alarm of increasing priority

13.3 – Block Error

Each Block implemented in the device contains a Standard BLOCK ERROR variable defined as bit string of 16 errors see below. Not all the errors condition are supported by all the different blocks

STANDARD BLOCK ERROR TABLE		
Byte	Bit	Mnemonic
1	0	Other
	1	Block Configuration error
	2	Link Configuration error
	3	Simulate active
	4	Local Override
	5	Device Fault State Set
	6	Device needs maintenance soon
	7	Input Failure/process variable has BAD status
2	0	Output Failure
	1	Memory failure
	2	Lost Static Data
	3	Lost NV Data
	4	Read-back check failed
	5	Device needs maintenance now
	6	Power up
	7	Out-of-Service

The following tables represent the BLOCK ERROR of each block implemented in the 2600T-2641B, with only the description of the supported error conditions and indication of which errors enable the Alert Notification mechanism depending by the correspondent "Alarm Priority" selection. Additionally is reported the Display indication and the kind of Status associated with the Output from the specific block.

Table E: TRANSDUCER BLOCK DISPLAY - BLOCK ERROR TABLE

Byte	Bit	Mnemonic	Alert Event	Description	Checking	LCD DISPLAY
2	1	Memory failure	YES	A memory failure has been detected in the Electronics EEPROM	At every the EEPROM (non-volatile memory) writing there is a checking that the values have been effectively burned in. If the value is not written correctly, a memory failure error is produced	
	7	Out-of-Service	YES	The TARGET MODE of the TB has been set to Out Of Service by the operator	The Actual_Mode of the TB is set to OUT OF SERVICE	OUT OF SERVICE

Table F: MUX - BLOCK ERROR TABLE

Byte	Bit	Mnemonic	Alert Event	Description	Checking	LCD DISPLAY
1	1	Block Configuration error	YES	The MUX is not properly configured for the selection of the variable to be displayed	1- if IN_SELECT = 0 2- if SEQUENCE = 0	OUT OF SERVICE
2	7	Out-of-Service	YES	The TARGET MODE of the TB has been set to Out Of Service by the operator	The Actual_Mode of the TB is set to OUT OF SERVICE	OUT OF SERVICE

Table G: RESOURCE - BLOCK ERROR TABLE

Byte	Bit	Mnemonic	Alert Event	Description	Checking	LCD DISPLAY
2	2	Lost Static Data	NO	The FB application configuration data have been lost. I.e. Link Objects, FB start List, Macrocycle, LAS data and so on.	CRC check during the start up	
	6	Power up	YES	The transmitter has just been powered on.	Each occurrence is counted by a dedicated counter TB_POWER_ON_CNT	LOST NV MEM
	7	Out-of-Service	YES	The TARGET MODE of the RB has been switched in Out Of Service by the operator	The Actual_Mode of the RB is set to OUT OF SERVICE <i>All the Actual_Mode of the other.blocks is forced to Out of Service too.</i>	

Table H: EPID - BLOCK ERROR TABLE

Byte	Bit	Mnemonic	Alert Event	Description	Checking	Propagation on PID_OUT_VALUE Status
1	1	Block Configuration error	NO	The PID has set to 0 parameters requiring a value different by 0 (Initial Value).	- If SHED_OPT = 0 - If BYPASS = 0 - if OUT_HI_LIM =< OUT_LO_LIM - if SP_HI_LIM =< SP_LO_LIM	BAD + Out Of Service See Note A
	4	Local Override	NO	The actual mode is LO	Actual Mode = Local Override	
	7	Input Failure/process variable has BAD status	YES	The Process Variable linked in input at the IN variable of the PID has the Status byte set to BAD	BAD quality Status in input at the PID_IN.	Depending also by the PID_STATUS_OPTS
2	7	Out-of-Service	YES	The TARGET MODE of the PID has been switched in Out Of Service by the operator	The Actual_Mode of the PID is set to OUT OF SERVICE	BAD + Out Of Service

Table L: INPUT SELECTOR - BLOCK ERROR TABLE

Byte	Bit	Mnemonic	Alert Event	Description	Checking	Propagation on IS_OUT_VALUE Status
1	1	Block Configuration error	NO	The IS has set to 0 parameters requiring a value different by 0 (Initial Value).	- If SELECT_TYPE = 0	BAD + Out Of Service See Note A
2	7	Out-of-Service	YES	The TARGET MODE of the IS has been switched in Out Of Service by the operator	The Actual_Mode of the IS is set to OUT OF SERVICE	BAD + Out Of Service

Table M: CONTROL SELECTOR - BLOCK ERROR TABLE

Byte	Bit	Mnemonic	Alert Event	Description	Checking	Propagation on CS_OUT_VALUE Status
1	1	Block Configuration error	NO	The CS has set to 0 parameters requiring a value different by 0 (Initial Value).	- If SEL_TYPE = 0	BAD + Out Of Service See Note A
2	7	Out-of-Service	YES	The TARGET MODE of the CS has been switched in Out Of Service by the operator	The Actual_Mode of the CS is set to OUT OF SERVICE	BAD + Out Of Service

Table N: ARITHMETIC - BLOCK ERROR TABLE



Byte	Bit	Mnemonic	Alert Event	Description	Checking	Propagation on AR_OUT_VALUE Status
1	1	Block Configuration error	NO	The AR has set to 0 parameters requiring a value different by 0 (Initial Value).	- If ARITH_TYPE = 0 - If GAIN = 0 - If COMP_HI_LIM =< COMP_LO_LIM and ARITH_TYPE in the range 1-5 - If BAL_TIME =< macrocycle and different by 0 At least one of the inputs used in the Output calculation is not **usable:	BAD + Out Of Service See Note A
	7	Input Failure/process variable has BAD status	YES	The variables linked in input at the AR have the Status byte set to BAD	**usable: For the inputs IN and IN_LO the usable status is: - GOOD_NC, GOOD_C, UNCERTAIN with INPUT_OPTION = Use uncertain	The worst of the used inputs
2	7	Out-of-Service	YES	The TARGET MODE of the AR has been switched in Out Of Service by the operator	The Actual_Mode of the AR is set to OUT OF SERVICE	BAD + Out Of Service

NOTE A: The specific block cannot be switched out from OUT OF SERVICE due to the Configuration Error. The Bad-Configuration Error Status is overridden by the Bad-Out Of Service Status.

13.4 – TROUBLESHOOTING:

The following tables list the most common problems that could occur and the possible cause and solutions.

MUX Block and DISPLAY Transducer Block Troubleshooting

PROBLEM	POSSIBLE CAUSE	SOLUTION
 The Display shows the string “ OUT OF SERVICE ”	The Target Mode is not set to AUTO The Configuration Error bit is set in the BLOCK_ERR	Set the Target Mode to AUTO and/or remove the OOS Set the MUX_SEQUENCE to values different by 0 Set the MUX_IN_SELECT with a value in the range 1-9 with the Configuration tool (Host)
 The Display shows the string “ INPUT NO LINK ”	The RESOURCE BLOCK is not in AUTO mode The Block is not scheduled The selected input to be displayed is not linked to another block	Set the Target Mode of the RESOURCE BLOCK to AUTO mode Design the FB Application correctly and download it to the devices Check the FB Application and download it to the devices again
 The Display shows the string “ LOST NV MEM ”	Corruption of the NV memory data have been detected	Try to restart again the device. If nothing changes try a cold start-up. If nothing changes again the electronics should be replaced

IS Function Block Troubleshooting

PROBLEM	POSSIBLE CAUSE	SOLUTION
The Block cannot be removed from OOS mode	The Target Mode is not set to AUTO The Configuration Error bit is set in the BLOCK_ERR The RESOURCE BLOCK is not in AUTO mode The Block is not scheduled	Set the Target Mode to AUTO and/or remove the OOS Set the SELECT_TYPE with a valid value. It must be different by 0 and in the range 1 –5 Set the Target Mode of the RESOURCE BLOCK to AUTO mode Design the FB Application correctly and download it to the devices
The OUT Status is BAD	All the Inputs have a BAD status The number of inputs with GOOD status is less than the MIN_GOOD value The OP_SELECT is different by 0 and force in output and Input with BAD status	Check the upstream blocks
Block Alarm Not Working (Events not notified)	The FEATURE_SEL has not the Reports bit Set LIM_NOTIFY value is less of the MAX_NOTIFY value	Set the REPORTS bit in the FEATURE_SEL of the RESOURCE BLOCK Set the value of LIM_NOTIFY equal, at least, to the MAX_NOTIFY value

CS Function Block Troubleshooting

PROBLEM	POSSIBLE CAUSE	SOLUTION
The Block cannot be removed from OOS mode	The Target Mode is not set to AUTO	Set the Target Mode to AUTO and/or remove the OOS
	The Configuration Error bit is set in the BLOCK_ERR	<ul style="list-style-type: none"> - Set the SEL_TYPE with a valid value. It must be different by 0 and in the range 1 – 3 - Set OUT_HI_LIM > OUT_LO_LIM
	The RESOURCE BLOCK is not in AUTO mode	Set the Target Mode of the RESOURCE BLOCK to AUTO mode
	The Block is not scheduled	Design the FB Application correctly and download it to the devices
	An used input has Bad Status	Check the upstream blocks
The Block is in MAN mode	The Selected input has UNCERTAIN Status	Set the STATUS_OPTS to Use Uncertain as Good
	There are no inputs linked in (OUT Status = BAD Configuration Error)	Review the FB application design
The OUT Status is BAD	The FEATURE_SEL has not the Reports bit Set	Set the REPORTS bit in the FEATURE_SEL of the RESOURCE BLOCK
Block Alarm Not Working (Events not notified)	LIM_NOTIFY value is less of the MAX_NOTIFY value	Set the value of LIM_NOTIFY equal, at least, to the MAX_NOTIFY value

AR Function Block Troubleshooting

PROBLEM	POSSIBLE CAUSE	SOLUTION
The Block cannot be removed from OOS mode	The Target Mode is not set to AUTO	Set the Target Mode to AUTO and/or remove the OOS
	The Configuration Error bit is set in the BLOCK_ERR	<ul style="list-style-type: none"> - Set the ARITH_TYPE with a valid value. It must be different by 0 and in the range 1 – 9 - Set the GAIN with value different by 0 - Set COMP_HI_LIM > COMP_LO_LIM when ARITH_TYPE in the range 1-5 - Set BAL_TIME > of the Macrocycle IF different by 0
	The RESOURCE BLOCK is not in AUTO mode	Set the Target Mode of the RESOURCE BLOCK to AUTO mode
	The Block is not scheduled	Design the FB Application correctly and download it to the devices
	At least one of used inputs have a BAD status	Check the upstream blocks
The OUT Status is BAD	The worst status of the used inputs is UNCERTAIN	Check the upstream blocks
	The FEATURE_SEL has not the Reports bit Set	Set the REPORTS bit in the FEATURE_SEL of the RESOURCE BLOCK
Block Alarm Not Working (Events not notified)	LIM_NOTIFY value is less of the MAX_NOTIFY value	Set the value of LIM_NOTIFY equal, at least, to the MAX_NOTIFY value

EPID Function Block Troubleshooting

PROBLEM	POSSIBLE CAUSE	SOLUTION
The Block cannot be removed from OOS mode	The Target Mode is not set different of OOS	Set the Target Mode to something different by OOS
	The Configuration Error bit is set in the BLOCK_ERR	<ul style="list-style-type: none"> - Set the OUT_HI_LIM > OUT_LO_LIM - Set the SP_HI_LIM > SP_LO_LIM - Set BYPASS to ON or OFF but different by 0 (uninitialized) - Set SHED_OPT different by 0
	The RESOURCE BLOCK is not in AUTO mode	Set the Target Mode of the RESOURCE BLOCK to AUTO mode
	The Block is not scheduled	Design the FB Application correctly and download it to the devices
The Block cannot be removed from IMAN mode	Something wrong in the BKCAL_IN	<ul style="list-style-type: none"> - The Status received in input of the BKCAL_IN is BAD Not Connected. Configure the link with the downstream block - The downstream block is producing a BAD status or Not Invited. Check the reason on the downstream block
	The Target Mode is not set to AUTO	Set the Target Mode to AUTO
The Block cannot be switched in AUTO mode	Something wrong in the IN	<ul style="list-style-type: none"> - The Status received in input of the IN is BAD Not Connected. Configure the link with the upstream block - The upstream block is producing a BAD status or Not Invited. Check the reason on the upstream block
	The Target Mode is not set to CASCADE	Set the Target Mode to CASCADE
The Block cannot be switched in CAS mode	Something wrong in the CAS_IN	<ul style="list-style-type: none"> - The Status received in input of the CAS_IN is BAD Not Connected. Configure the link of the CAS_IN with another block - The upstream block is producing a BAD status or Not Invited. Check the reason on the upstream block
	The Target Mode is not set to CASCADE	Set the Target Mode to CASCADE
Block Alarm Not Working (Events not notified)	The FEATURE_SEL has not the Reports bit Set	Set the REPORTS bit in the FEATURE_SEL of the RESOURCE BLOCK
	LIM_NOTIFY value is less of the MAX_NOTIFY value	Set the value of LIM_NOTIFY equal, at least, to the MAX_NOTIFY value
	STATUS_OPTS has the Propagate Fault Forward bit Set	This bit should be cleared for producing the alarm

13.5 - Status Supported

The FOUNDATION™ Fieldbus defines a Status Byte to be produced together with the dynamic variables like the FB Outputs. The Status byte represents the quality of the Value as GOOD, UNCERTAIN or BAD plus the sub-status describing the reasons for having such quality and it is the fifth byte of the record including the Variable's Value.

For specific details about meaning of any single sub-status refer to the **Function Block Part 1 (Ref. 1) section 4.4.1**

		Quality		Substatus				Limits		
Dec	Hex	Gr	Gr	QS	QS	QS	QS	Qu	Qu	
		2 ⁷	2 ⁶	2 ⁵	2 ⁴	2 ³	2 ²	2 ¹	2 ⁰	
0	00	0	0							= bad
64	40	0	1							= uncertain
128	80	1	0							= good (Not Cascade)
192	C0	1	1							= good (Cascade)

Details for BAD

0	00	0	0	0	0	0	0			= non-specific
4	04	0	0	0	0	0	1			= configuration error
8	08	0	0	0	0	1	0			= not connected
12	0C	0	0	0	0	1	1			= device failure
16	10	0	0	0	1	0	0			= sensor failure
20	14	0	0	0	1	0	1			= no communication with LUV
24	18	0	0	0	1	1	0			= no communication no LUV
28	1C	0	0	0	1	1	1			= out of service

Details for UNCERTAIN

64	40	0	1	0	0	0	0			= Non-specific
68	44	0	1	0	0	0	1			= Last Usable Value
72	48	0	1	0	0	1	0			= substitute set
76	4C	0	1	0	0	1	1			= Initial Value
80	50	0	1	0	1	0	0			= sensor conversion not accurate
84	54	0	1	0	1	0	1			= engineering unit range violation
88	58	0	1	0	1	1	0			= Sub-normal

Details for GOOD (non-cascade)

128	80	1	0	0	0	0	0			= ok
132	84	1	0	0	0	0	1			= active block alarm
136	88	1	0	0	0	1	0			= active advisory alarm
140	8C	1	0	0	0	1	1			= active critical alarm
144	90	1	0	0	1	0	0			= unacknowledged block alarm
148	94	1	0	0	1	0	1			= unacknowledged advisory alarm
152	98	1	0	0	1	1	0			= unacknowledged critical alarm

Details for GOOD (cascade)

192	C0	1	1	0	0	0	0			= ok
196	C4	1	1	0	0	0	1			= initialisation acknowledge
200	C8	1	1	0	0	1	0			= initialisation request
204	CC	1	1	0	0	1	1			= not invited
208	D0	1	1	0	1	0	0			= not selected
212	D4	1	1	0	1	0	1			= reserved
216	D8	1	1	0	1	1	0			= Local Override
220	DC	1	1	0	1	1	1			= Fault state active
224	E0	1	1	1	0	0	0			= Initiate fault state

Details for bits 'LIMITS'

+0	+00							0	0	= ok
+1	+01							0	1	= low limited
+2	+02							1	0	= high limited
+3	+03							1	1	= constant

If more than one condition is present, only the one with higher priority is reported. The priority level is in the following order:

- BAD
- GOOD (Cascade)
- UNCERTAIN
- GOOD (Not Cascade)

Into any single quality group the priority level is relating to the value. (i.e. BAD - Out of Service is the higher priority and GOOD – OK is the lower priority)

14. – Device Specification Data

The delivery of the 2600T-264IB FF includes the DD file (*.sym, *.ffo files) and the Capability file (.CFF file).

The following table is a summary of the most important 2600T-264IB FF specification data

Manufacturer	ABB
Device Model	2600T Series – Models 264IB FOUNDATION Fieldbus
Device Application	Multivariable Field Indicator
Device Type	Link Master Device
Output Signal	Physical layer compliant to the standard IEC 1158-2
Communication speed	31.25 Kbit/second
Electrical Signal	Manchester Code II
Power supply	Bus Powered: 9 – 32 Vdc limited to: 24 Vdc for ENTITY IS certification 17.5 Vdc for FISCO IS Certification
Interface	FOUNDATION™ Fieldbus H1 Compliant with specification V 1.4
Blocks implemented	2 Enhanced PID, 1 Enhanced Resource, 1 Custom Arithmetic, 1 Custom Input Selector, 1 Custom Control Selector, 1 Custom Multiplexer Block, 1 Custom Display Transducer Blocks
FB Execution period	E-PID = 25mS IS = 10mS CS = 10mS AR = 10mS MUX = 1mS
LAS functionality	1 sub-schedule, 96 sequences, 25 elements for sequence
Number of link objects	35
Number of VCRs	35
Current consumption	10.5 mA max
Fault Current limiting	20 mA
FF Registration	IT0025500
IS Certificate	ATEX, FM, CSA, according to both ENTITY and FISCO recommendations See section 3.1 – Environmental protection
Max. Temperature	-40 / +85 °C
Remote Configuration tools	Via tools using DD & CFF Files

15. - Reference -

- 1- Function Block Application Process – Part 1. n° FF-890- Revision 1.4 dated June 29, 1999
- 2- Function Block Application Process – Part 2 n° FF-891- Revision 1.5 dated October 28, 2001
- 3- Function Block Application Process – Part 3 n° FF-892- Revision 1.5 dated November 5, 2001

APPENDIX A

2600T-264IB FF Electronic Replace

The following Steps have to be followed for the FF electronic replacement:

- 1- Remove the cover with the glass
- 2- Remove the 2 screws of the electronic.
- 3- Extract the electronics from the housing.
- 4- Remove the LCD meter, (be carefully with the plastic clips)
- 5- Take the new unit and put the switch 3 (cold Start-up) in ON position. Do not connect, for the moment, the LCD meter !!!!
- 6- Insert the new unit into the housing (be carefully with the two in-housing jack connectors)
- 7- Power on the transmitter and keep it powered-on for few seconds (about 10).
- 8- Power-Off the transmitter again, and put the switch 3 in OFF position.
- 9- Insert the LCD meter, (be carefully with the 8 pins connector). May be it is easier to remove the electronic again from the Housing for the connection of the LCD meter.
- 10-Fix the electronics with the two screws and mount the glass cover again.

The operation is now completed and the device should work with default configuration.

The engineering unit for all the inputs is % and the TAG is Blank.

No Input of the MUX is selected (Channel = 0)

The Target Mode for all the Function Blocks is Out Of Service. The user has to set the AUTO Mode for the RB first, and then for the other blocks.

PRODUCTS & CUSTOMER SUPPORT

Products

Automation Systems

- *for the following industries:*
 - Chemical & Pharmaceutical
 - Food & Beverage
 - Manufacturing
 - Metals and Minerals
 - Oil, Gas & Petrochemical
 - Pulp and Paper

Drives and Motors

- *AC and DC Drives, AC and DC Machines, AC Motors to 1kV*
- *Drive Systems*
- *Force Measurement*
- *Servo Drives*

Controllers & Recorders

- *Single and Multi-loop Controllers*
- *Circular Chart, Strip Chart and Paperless Recorders*
- *Paperless Recorders*
- *Process Indicators*

Flexible Automation

- *Industrial Robots and Robot Systems*

Flow Measurement

- *Electromagnetic Magnetic Flowmeters*
- *Mass Flow Meters*
- *Turbine Flowmeters*
- *Wedge Flow Elements*

Marine Systems & Turbochargers

- *Electrical Systems*
- *Marine Equipment*
- *Offshore Retrofit and Refurbishment*

Process Analytics

- *Process Gas Analysis*
- *Systems Integration*

Transmitters

- *Pressure*
- *Temperature*
- *Level*
- *Interface Modules*

Valves, Actuators and Positioners

- *Control Valves*
- *Actuators*
- *Positioners*

Water, Gas & Industrial Analytics Instrumentation

- *pH, conductivity, and dissolved oxygen transmitters and sensors*
- *ammonia, nitrate, phosphate, silica, sodium, chloride, fluoride, dissolved oxygen and hydrazine analyzers.*
- *Zirconia oxygen analyzers, katharometers, hydrogen purity and purge-gas monitors, thermal conductivity.*

Customer Support

We provide a comprehensive after sales service via a Worldwide Service Organization. Contact one of the following offices for details on your nearest Service and Repair Centre.

Italy

ABB S.p.A.
Business Unit Measurement Products
Tel: +39 0344 58111
Fax: +39 0344 56278

United Kingdom

ABB Limited
Tel: +44 (0)1453 826661
Fax: +44 (0)1453 827856

United States of America

ABB Inc.
Tel: +1 (0) 755 883 4366
Fax: +1 (0) 755 883 4373

Client Warranty

Prior to installation, the equipment referred to in this manual must be stored in a clean, dry environment, in accordance with the Company's published specification.

Periodic checks must be made on the equipment's condition. In the event of a failure under warranty, the following documentation must be provided as substantiation:

1. A listing evidencing process operation and alarm logs at time of failure.
2. Copies of all storage, installation, operating and maintenance records relating to the alleged faulty unit.

ABB has Sales & Customer Support
expertise in over 100 countries worldwide

www.abb.com/instrumentation

The Company's policy is one of continuous product
improvement and the right is reserved to modify the
information contained herein without notice.

Printed in Italy (10.06)

© ABB 2012



ABB Ltd
Howard Road, St. Neots
Cambridgeshire, PE19 3EU
UK
Tel: +44(0)1480 475321
Fax: +44(0)1480 217948

ABB Inc.
125 E. County Line Road
Warminster, PA 18974
USA
Tel: +1 215 674 6000
Fax: +1 215 674 7183

ABB S.p.A.
Via Statale 113
22016 Lenno (CO)
Italy
Tel: +39 0344 58111
Fax: +39 0344 56278